



October 30, 2024

INVITATION TO BID  
BL139-24

The Gwinnett County Board of Commissioners is soliciting competitive sealed bids from qualified contractors for the **Resurfacing of Major County Roads on a Term Contract** for the Department of Transportation.

Bids should be typed or submitted in ink and returned in a sealed container marked on the outside with the BL# and Company Name. Bids will be received until **2:50 P.M. local time on November 13, 2024** at the Gwinnett County Financial Services – Purchasing Division – 2<sup>nd</sup> Floor, 75 Langley Drive, Lawrenceville, Georgia 30046. Any bid received after this date and time will not be accepted. Bids will be publicly opened and read at 3:00 P.M. Apparent bid results will be available the following business day on our website [www.gwinnettcounty.com](http://www.gwinnettcounty.com).

A **pre-bid conference** is scheduled for **10:00 A.M. on November 4, 2024**, at the DOT Central, 620 Winder Hwy, Lawrenceville, GA 30045. All bidders are strongly urged to attend.

**Questions** regarding bids should be directed to Michael Milstein, Purchasing Associate II, at [Michael.Milstein@gwinnettcounty.com](mailto:Michael.Milstein@gwinnettcounty.com) or by calling **770-822-7811** no later than **3:00 p.m. November 5, 2024**. Bids are legal and binding upon the bidder when submitted. All bids should be submitted in duplicate.

Successful vendors will be required to meet insurance requirements. The Insurance Company should be authorized to do business in Georgia by the Georgia Insurance Department and must have an A.M. Best rating of A-5 or higher.

All contractors must submit with bid, a bid bond, certified check or cashier's check in the amount of five percent (5%) of the total bid made payable to the Gwinnett County Board of Commissioners. **Failure to submit a bid bond with the proper rating will result in the bid being deemed non-responsive.** Successful supplier will be required to meet insurance requirements, submit a one hundred percent (100%) performance bond and a one hundred percent (100%) payment bond. Insurance and Bonding Company should be licensed to do business by the Georgia Secretary of State, authorized to do business in Georgia by The Georgia Insurance Department, listed in the Department of Treasury's Publication of Companies holding Certificates of Authority as Acceptable Surety on Federal Bonds and as acceptable reinsuring companies. **The bid bond, payment bond, and performance bond must have an A.M. Best rating of A-5 or higher.**

Gwinnett County does not discriminate on the basis of disability in the admission or access to its programs or activities. Any requests for reasonable accommodations required by individuals to fully participate in any open meeting, program or activity of Gwinnett County Government should be directed to the ADA Coordinator at the Gwinnett County Justice and Administration Center, 770-822-8165.

The written bid documents supersede any verbal or written prior communications between the parties. Award will be made to the contractor submitting the lowest responsive and responsible bid. Gwinnett County reserves the right to reject any or all bids, to waive technicalities, and to make an award deemed in its best interest. Bids may be split or awarded in entirety. Gwinnett County reserves the option to negotiate terms, conditions and pricing with the lowest responsive, responsible bidder(s) at its discretion.

Award notification will be posted after award on the County website, [www.gwinnettcounty.com](http://www.gwinnettcounty.com) and companies submitting a bid will be notified via e-mail. We look forward to your bid and appreciate your interest in Gwinnett County.

Sincerely,

Michael Milstein  
Purchasing Associate II

The following pages **should** be returned as part of your bid:

**Bid Schedule, Pages 16-20**  
**References, Page 21**  
**Sub-Contractor List, Page 22**  
**Bid Bonds, Pages 25-26**  
**Ethics Affidavit, Page 38**  
**E-verify Affidavit, Page 39**

## RESURFACING OF MAJOR COUNTY ROADS ON A TERM CONTRACT

BIDDERS ARE ADVISED TO THOROUGHLY UNDERSTAND THE GENERAL CONDITIONS AND SPECIAL PROVISIONS, PRIOR TO SUBMITTING THEIR BID.

### I. GENERAL CONDITIONS

#### A. QUALIFICATIONS

1. Bids will be considered only from experienced and well-equipped Contractors engaged in work of this type and magnitude.
2. Bidders may be required to submit evidence setting forth qualifications, which entitle him to consideration as a responsible Contractor. A list of work of similar character successfully completed within the last two years may be required giving the location, size, and listing equipment available for use on this work. Before accepting any bid, the County may require evidence of the Contractor's financial ability to successfully perform the work to be accomplished under the contract.
3. **Status as a Georgia DOT certified, and prequalified contractor is one of the factors to be considered in determining qualification for this bid.**

#### B. GUARANTEE TO ACCOMPANY BID

1. Bids must be accompanied by a certified check or cashier's check or acceptable bid bond (Gwinnett County form provided) in an amount not less than five percent (5%) of the total amount bid per section and made payable to Gwinnett County Board of Commissioners. Failure to use Gwinnett County form may result in bid being deemed non-responsive. Failure to submit a bid bond or certified check or cashier's check will be cause for rejection.

#### C. JOINT VENTURES AND SUB-CONTRACTING

Joint Ventures between two contractors will NOT be allowed in any section. Subletting will be allowed up to 30% of the actual paving/patching work which includes all mixes (9.5mm mix Types I and II, and 12.5mm Gp 2 mix, Leveling, and 12.5 mm Patching) for this contract. This will be based on the estimated combined tonnage for these items on this contract. The contractor will have the option to apply this to any or all items listed in the schedule of items without exceeding the 30% of combined tonnage. Any subcontractor listed must be approved by Gwinnett County DOT prior to doing any work and be registered with Georgia Department of Transportation (GDOT).

Subletting additional items (milling, crack filling, structure adjustment, and pavement markings) will be allowed and shall be in accordance with Section 108.01 of the Standard Specifications of the Georgia Department of Transportation.

#### D. SUBMITTING BIDS

1. Bids should be submitted in envelope with the following information clearly typed or printed on the outside:  
Gwinnett County Purchasing Division  
Resurfacing of County Roads  
Bid Number and Section  
Date of Bid Opening  
Company Name

#### E. AUTHORITY TO SIGN

The contractor should ensure that the legal and proper name of his proprietorship, firm, partnership or corporation is printed or typed in the space provided on the Schedule of Items.

#### F. RIGHTS RESERVED

1. Bidders are advised to examine the Plans and Specifications carefully and to make examinations of the site of the proposed work as are necessary to familiarize themselves with local conditions, which may affect the proposed work. Bidders are also advised to inform themselves fully in regard to conditions under which the work will be performed. Gwinnett County will not be responsible for Bidder's errors or misjudgment, nor for any information on local conditions or general laws and regulations.

2. Any unauthorized additions, conditions, limitations, or provisions attached to the Bid shall render it informal and may be cause for rejection.
3. Individuals, firms and businesses seeking an award of a Gwinnett County contract may not initiate or continue any verbal or written communications regarding a solicitation with any County officer, elected official, employee or other County representative without permission of the Purchasing Associate named in the solicitation between the date of the issuance of the solicitation and the date of the final contract award by the Board of Commissioners. The Purchasing Director will review violations. If determined that such communication has compromised the competitive process, the offer submitted by the individual, firm or business may be disqualified from consideration for award.

G. AWARD OF CONTRACT

1. The Contract will be an "Open End" type to provide for the requirements of Gwinnett County on an as needed basis. As it is impossible to determine the exact quantities of items and the roads, parking areas, etc., to receive these items, either for resurfacing or new roads, the quantities of items may be increased or decreased, and specific roads may be added or deleted as required to satisfy the needs of the County. Each section will be awarded to the lowest, responsive and responsible bidder. Gwinnett County reserves the right to make an award as deemed in its best interest, which may include awarding to a single bidder or multiple bidders.
2. Prior to award of the contract, the successful contractor may be required to submit a construction schedule to the County, demonstrating the contractor's ability to commence and proceed in a timely manner on all of the Gwinnett County resurfacing contracts for which contractor is the successful bidder. Due to the time constraints on this contract, it is mandatory that the work be performed as quickly as possible. A contractor's failure to demonstrate the ability to proceed as required may result in the award of going to the next low, responsive and responsible bidder, as deemed in the County's best interest.
3. Prior to execution of a contract, a Contract Performance Bond and a Payment Bond, each equal to 100% of the Contract amount per section, must be provided by the successful Bidder (Gwinnett County form provided) by a surety company qualified to do business in the State of Georgia and satisfactory to Gwinnett County. Bonds given shall meet the requirements as listed in this Bid package. Failure to execute the Contract, Contract Performance Bond and Payment Bond, or furnish satisfactory proof of coverage of the insurance required within ten days after the date of Notice of the Contract may be just cause for the annulment of the award and for the forfeiture of the guaranty to Gwinnett County, not as a penalty, but as liquidation of damages sustained. Failure to progress in a timely manner after beginning the work may also be just cause for annulment of the contract award and re-advertisement and re-bidding of any or all of these contracts. The Contract and Contract Bonds shall be executed induplicate.

H. TERM

Contract will begin on the issuance date of the Notice to Proceed and continue through **December 31, 2025.** However, for any order to pave and/or resurface any given roads, parking areas, etc., mailed or received, if forwarded by other means than through the mail to the Contractor on or before the Contract expiration date, the Contractor will be required to perform such resurfacing within a time agreed to by both parties and at the Contract unit prices. Failure to perform such work in the time agreed will result in Liquidated Damages of \$1,000.00 per day until such work is completed.

I. PRODUCTION REQUIREMENTS

1. Time is of the utmost importance for this project. The successful bidder will be required to commence work within ten (10) calendar days from receipt of the Notice to Proceed and must carry on with utmost diligence in order to complete the work at the earliest possible date.
2. It is important that the work proceed promptly and continuously on the contract. In each Section, the contractor must meet or exceed the following production requirements and deadlines. If the contractor is awarded more than one section, the below requirements will be determined based on the cumulative total tonnage awarded, unless otherwise stated:
  - a) Within 120 calendar days following the issuance date of the Notice to Proceed, the contractor must place a minimum of 50% of the total tonnage awarded of 9.5 mm (**Type II**) and 12.5mm mixes for the roads listed in the Schedule of Items for this contract. Failure to reach the milestone in the time listed above will result in Liquidated Damages of \$500.00 per calendar day until such work is completed.

b) By October 31<sup>st</sup> of the current contract year, the contractor must place a minimum of 100% of the total tonnage of 9.5 mm (**Type II**) and 12.5mm mixes for major roads listed in the Schedule of Items, for each resurfacing section. Failure to reach the milestone in the time listed above will result in Liquidated Damages of \$1,000.00 per calendar day per section awarded until such work is completed.

c) The work hours are as follows:

Major Roads 9:00 AM - 4:00 PM

The contractor may request in writing modifications to the work hours listed above. Gwinnett County has the right to approve or deny a request or respond with an alternate. Gwinnett County reserves the right to adjust the work hours during the contract period.

J. RETAINAGE

The county shall retain 5% of the gross value of the completed work, indicated by current estimates, until all pay items are substantially completed.

K. LOCATION AND SITE

1. The site of the proposed work is at the stated location(s) within Gwinnett County, Georgia. A list of proposed roads is included in these specifications; maps will be available at the pre bid conference.
2. The successful Contractor shall accept the site in its present condition and carry out all work in accordance with the requirements of the specifications, as indicated on the drawings or as directed by the engineer.
3. The successful Contractor, before submitting a bid, is advised to visit the site, and acquaint himself with the actual conditions and the location of any or all obstructions that may exist on the site.
4. The Contract Documents contain the provisions required for the completion of the work to be performed pursuant to this Contract. Information obtained from an Officer, agent, or employee of Gwinnett County or any other person shall not affect the risks or obligations assumed by the Contractor or relieve Contractor from fulfilling any of the conditions of the Contract. All contractors submitting a bid are responsible for inspecting the site and for reading and being thoroughly familiar with the Contract Documents. The failure or omission of any Bidder to so familiarize himself shall in no way relieve any Bidder from any obligation in respect to his Bid.
5. The Contractor is responsible for the location of above and below ground utilities and structures, which may be affected by the work.

L. COMPLIANCE WITH OSHA STANDARDS AND REGULATIONS

The work connected with this Contract shall be performed in accordance with all applicable OSHA regulations and standards including any additions or revisions thereto until the job is completed and accepted by Gwinnett County.

M. MATERIALS

All materials furnished and/or installed by the Contractor shall be furnished only by Georgia Department of Transportation certified source and shall be within the limits, tolerances, formulae, etc., as established by the Georgia Department of Transportation.

N. INSPECTION

Gwinnett County does not commit to have a full-time inspection or testing of work while in progress or at sources of materials furnished. Any lack of inspection and/or testing will in no way relieve the Contractor of the responsibility to provide quality workmanship in accordance with the Specifications. Any test ordered under the supervision of the County that fails to meet standards and retesting is required will be at the contractor's expense.

O. CONTRACT REQUIREMENTS

1. Successful vendor is required to do the following within ten (10) days of Notice:
  - a) Return to Purchasing Office contract documents executed by the authorized representative and attested by the corporate secretary treasurer.

- b) Provide Insurance certificates as specified in the bid documents.
  - c) Provide bonding as required by the bid documents.
2. Failure to execute the Contract, Contract Performance Bond and Payment Bond, or furnish satisfactory proof of carriage of the insurance required within ten days after the date of Notice of Award of the Contract may be just cause for the annulment of the award and for the forfeiture of the bid guaranty Gwinnett County, not as a penalty, but as liquidation of damages sustained. At the discretion of the County, the award may then be made to the next lowest, responsible bidder, or the work may be re- advertised or constructed by County forces. The Contract and Contract Bonds shall be executed in duplicate.

**II. SPECIAL PROVISIONS**

**A. AREAS OF WORK**

- 1. The area of work for resurfacing will be within the limits defined on the County map. The work will be divided into three (3) sections: North, West, and South. Any roads added to the County's resurfacing program will be worked by the contractor's section, in which they are located.
- 2. This term contract covers only those existing roads scheduled for resurfacing by the Gwinnett County Road Maintenance Division, or being constructed by in-house construction forces, and in no way pertains to any asphalt work being performed on new construction or widening projects being built for Gwinnett County by private contractors.
- 3. The schedule of items for the entire section includes estimated quantities for this work.
- 4. The work will be divided into three (3) sections: North, West, and South. Please see Appendix A for the paving list and Appendix B for the Resurfacing Map.

**B. GEORGIA DEPARTMENT OF TRANSPORTATION**

Unless otherwise directed, all work performed under contract shall be in accordance with the Georgia Department of Transportation Standard Specifications, Construction of Roads, and Bridges, 2021 Edition, and any supplemental specification modifying them except as noted below and in the special provisions.

1. Modifications of Standard Specifications

Section 101	Definition of terms
Section 101.14 COMMISSIONER	Delete in its entirety.
Section 101.22 DEPARTMENT	Delete as written and substitute the following: THE GWINNETT COUNTY DEPARTMENT OF TRANSPORTATION
Section 101.24 (ENGINEER)	The Director of the Gwinnett County Dept. of Transportation, acting directly or through his duly authorized representative.
Section 101.26 EXTENSION AGREEMENT	Delete in its entirety
101.28 FORCE ACCOUNT	Delete in its entirety.
Section 400 HOT MIX ASPHALTIC	Delete in its entirety and substitute the SPECIAL PROVISION for section 400-HOT MIX ASPHALTIC CONCRETE CONSTRUCTION – ON SYSTEM. The only exception to this special provision shall be under section 400.3.06.B "Compaction" where density tests will not be required for material placed at 125 lbs/yd <sup>2</sup> or less rather than the referenced 90 lbs/yd <sup>2</sup> . Gwinnett County reserves the right to test for density on any and all asphalt placed regardless of spread rate if the contractor's compactive efforts do not appear sufficient or effective.

## Section 413.5 Bituminous Tack Coat

PAYMENT: Delete as written and substitute the following:

No separate payments will be made for this item. The cost for bituminous tack coat shall be included in the unit price bid as indicated in the Schedule of Items.

The work to be done under this contract includes only those existing roads scheduled for resurfacing by the Gwinnett County Road Maintenance Division and paid for solely with Gwinnett County and/or Georgia DOT LMIG funds. Any resurfacing that is to be paid for all or in part with Federal Funds, as part of a Stimulus package or similar program, WILL NOT be made a part of this contract. A separate, project-specific contract will be let for that Federally funded work, if applicable.

C. FEDERAL REGULATIONS

The Contractor must be in compliance with all applicable Federal regulation, including but not limited to the Davis-Bacon Act.

D. RECORDS

The Contractor is required to maintain and make available to Gwinnett County and auditors, complete records of the work covered, for the life of the contract and for three years thereafter. All tickets must show the road name where the mix was used.

E. GENERAL CONSTRUCTION GUIDELINES

1. The contractor shall be required to perform a minimum of 70% of the actual resurfacing paving work included in the Schedule of Items for each section (9.5mm mix Types I and II, and 12.5mm Gp II mix, Leveling, and 12.5mm Patching). A maximum of 30% of these items can be sublet to a qualified subcontractor, see section 1 (General Conditions), item A (Qualifications), item 3 and item C (Joint Ventures and Sub-Contracting). Contractor must demonstrate successful experience in placing at least 50,000 tons of surface mix using their own labor and equipment over the past 5 years, with at least 15,000 tons being on a single project. Subletting of the additional items (patching, milling, structure adjustment, crack filling, etc.) as well as actual paving work once the contractor has met or exceeded the quantities in the Schedule of Items (9.5mm mix Types II, and 12.5mm Gp 2 mix) shall be in accordance with Section 108.01 of the Standard Specifications of the Georgia Department of Transportation.
2. The contractor shall be required to give a minimum of 24 hours' notice to Gwinnett County or its representative before proceeding with paving on any road.
3. The contractor shall be required to provide a work schedule every Thursday during the course of the resurfacing contract to Gwinnett County or its representative. This paving schedule shall outline the anticipated work activities planned for the following week and locations in which this work will take place.
4. Prior to beginning the patching work (or paving work if there is no patching), the Contractor shall install the appropriate post-mounted road construction signs on each non-residential road they are resurfacing. These signs will remain in place until approved for removal by the Engineer.
5. Control and testing of materials will be the contractor's responsibility for all mix provided in accordance with sections 106, 400, 402, 820 and related special provisions of the Georgia Department of Transportation Standard Specifications. The cost of such testing shall be included in the unit price of the material being used, and no additional compensation will be made.
6. All driveways and intersections shall be tied-in with surface mix at the time of paving for a sufficient distance to provide a smooth transition from the new pavement to the existing surface.

Unless approved by the Engineer, all intersections will be pulled back a minimum of a spreader length (12'). Speed humps shall be removed by the contractor as directed by the Engineer and signage provided by the county shall be posted prior to removal work begins. The tied-in area shall be cleaned and tacked prior to paving, and the material placed and compacted in such a manner to eliminate edge raveling. Gwinnett County will utilize its speed hump contractor to reinstall speed humps within 30 days of the completion of the topping.

7. The contractor shall furnish, install, maintain and remove all necessary traffic signs, barricades, lights, signals,

cones and other traffic control devices, and all flagging and other means of traffic protection and guidance as required by the Standard Specifications of the Georgia Department of Transportation, (Included in Documents). Contractor will be required to install message boards on 16 Major roads as requested by the engineer. Message boards should read Road Work to Begin on DD/MM/YY Expect Delays, and be installed 5 days prior to and remain during the milling and patching process and the resurfacing process. Such work shall be considered incidental to the overall contract, and no additional compensation will be made.

**The sixteen (16) major roads that requires two (2) message boards to be posted on each road.**

North Section	South Section	West Section
Ridge Road	Pinehurst Road	Old Peachtree Road (4)
Old Peachtree Road	Skyland Drive	Fork Creek Parkway
Suwanee Dam Road	Hoke O’Kelly Mill Road	Boggs Road
Mall of Georgia Boulevard	Sugarloaf Parkway	Satellite Boulevard
Sunny Hill Road	Old Loganville Road	South Old Peachtree Road
Fence Road		Jimmy Carter Boulevard

8. On roads without curb and gutter, where the contractor is directed by the Engineer not to perform the Shoulder Reconstruction pay item, the contractor shall be required to knock down any windrows created by the clipping operation. This work shall be done following resurfacing, at such time that the mix has sufficiently cured to prevent damage. Such work shall be incidental to the cost of the resurfacing work being performed and no additional payment shall be made.
9. The contractor will be required to re-establish the traffic pavement marking in accordance with the details in the special provisions.

F. HYDRATED LIME

Hydrated Lime must be included and be in accordance with Section 828.2 of the Georgia Department of Transportation Standard Specifications, Construction of Roads and Bridges, 2021 Edition.

G. ROAD PATCHING

1. Road Patching, as described herein, shall apply to the removal and replacement of failed areas, as indicated by the Engineer, on roads scheduled for resurfacing.
2. The "Road Patching" work is intended to cover the removal and replacement of relatively small failed areas of pavement. Removal and replacement of a single section which is at least full lane width and 59 feet in length will not be paid as patching, but instead, at the bid unit prices for "Mill asphaltic Concrete - Variable Depth" and for the particular asphalt mix being used.
3. The County will provide the Contractor with a list of roads for patching, and pre-mark the areas to be patched.
4. The Contractor will give the County and public a minimum of 24 hours’ notice before proceeding on patching a particular road and proper posting of such work associated with resurfacing is required for the public.
5. **Milling cover up time is 30 days.** The contractor must place the required topping mix for major roads listed in the Schedule or Items for each resurfacing section. Failure to reach cover up the milled and patched roads within 30 days will result in Liquidated Damages of \$100.00 per calendar day per road until such work is completed.
6. The required procedures for patching Bituminous Asphaltic Concrete roads shall be as follows:

- a) Areas to be patched shall be milled using an approved milling machine. Contractor shall have available a 4 foot milling machine to maximize efficiency.
- b) Material shall normally be removed to a required depth of 3". Where existing pavement thickness causes more than the required depth to be removed, the additional depth shall be inspected and approved by the Engineer prior to placing the asphalt. Less milling may be allowed, but must be approved by the Engineer prior to placing the asphalt.
- c) Where unsuitable material exists below the required depth, the contractor will notify the Engineer prior to placing asphalt so a decision can be made as to the method of dealing with the unsuitable material. When directed by the Engineer, the Contractor shall remove the unsuitable material and replace it with Graded Aggregate Base, which will then be leveled to the appropriate grade.
- d) The base and edges around the patch shall be tack coated using approved material.
- e) Patch material, Bituminous Asphaltic Concrete, shall be compacted using approved equipment. Prior to starting any work, the County shall approve the job mix design.
- f) The existing pavement surface shall be cleaned to remove all loose patching related materials, upon completion of the day's work, using suitable equipment.

7. The above patching operations shall be paid for as follows:

Bituminous Asphaltic Concrete Roads: Will be paid at the Unit price bid for Asphalt Concrete Patching, 12.5mm, and shall cover all work required; including milling, removal and disposal of all existing material disturbed during the patching operation and any new loose material not incorporated into the patching on the same day; applying tack coat; placing and compacting new material and all required traffic control.

8. Gwinnett County reserves the right to perform any patching using in-house labor, as deemed practical.

#### H. MANHOLE ADJUSTMENT & WATER VALVE BOX ADJUSTMENT

- 1. All work shall be performed in accordance with the Georgia Department of Transportation Standard Specifications, Section 611.
- 2. The following procedure shall be used in the adjustment of the structures:
  - a) It shall be the Contractor's responsibility to note and mark the location of each water valve box and manhole covers on the streets to be resurfaced, prior to the resurfacing work then locate and adjust each of these after resurfacing.
  - b) Structures, both manholes and water valves, shall be adjusted within **30 days** after the road is resurfaced. Failure to do so will result in the assessment of Liquidated Damages in the amount of twenty-five dollars (\$25.00) per calendar day per structure for every day beyond this 30-day requirement.
  - c) The existing pavement will be removed a minimum of 9" outside the most exterior points of the structures.
  - d) Structures will be adjusted to pavement grade using bricks, shims or other non-organic material.
  - e) Concrete having a minimum compressive strength of 3000 p.s.i. at 28 days shall be placed around the adjusted structure, consolidated to fill the voids, and finished to pavement grade. Care should be taken to prevent concrete from falling into manholes, with any such material being removed by the contractor as soon as possible.
  - f) Concrete shall be protected from traffic for a minimum of 3 days with steel plates, or other measures as approved by the Engineer.
  - g) The unit prices bid for Manhole Adjustment and Water Valve Box Adjustment will be for all work performed, including excavation and disposal of existing material, adjustment of structure, traffic control, and protection of the concrete.

- h) The Contractor will give the County a minimum of 24 hours' notice as to the locations to be adjusted to allow for inspection scheduling.
- i) Gwinnett County reserves the right to adjust any structures using in-house labor as deemed practicable.
- j) In the event an existing casting or structure is found to be structurally deficient, it shall be reported to the engineer for evaluation.

I. ASPHALTIC CONCRETE PAVEMENT EDGE

- This work shall consist of constructing a pavement edge treatment as per Georgia Department of Transportation Construction Detail number P-7.
- Any additional labor or equipment necessary to place this pavement edge shall be considered incidental to the resurfacing operation, and no additional compensation will be made with the exception of the extra asphalt material being paid for at the bid unit price for the particular material being used.

**ASPHALT PAVEMENT - OVERLAY**

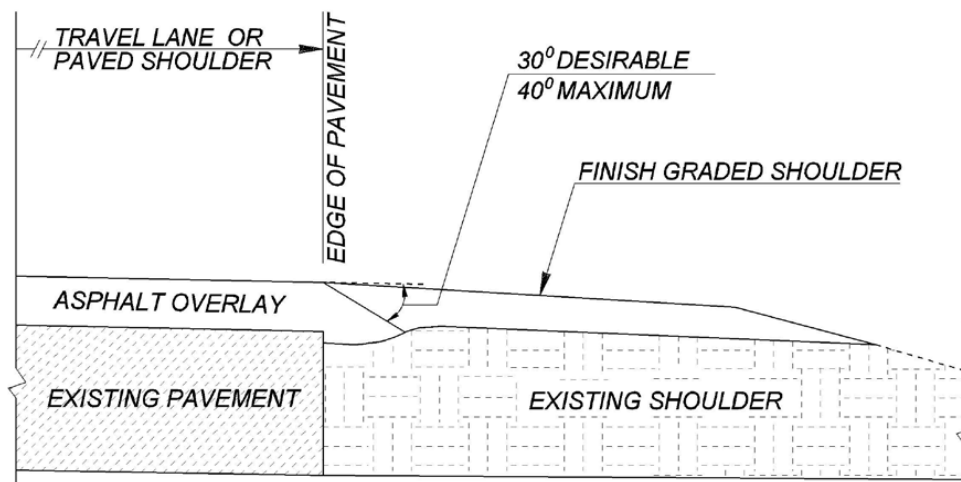

J. SHOULDER RECONSTRUCTION

- A. In general, the Shoulder Reconstruction work described herein shall be performed by the Contractor on every non-residential road they resurface, where curb and gutter is not present; unless otherwise directed in writing by the Engineer. This work shall consist of preparation, construction, grading, hydro seeding and maintaining grass shoulders adjacent to the pavement edge, on those particular roads designated in this contract. Unless specified otherwise within these special provisions, all work shall be in accordance with the Georgia Department of Transportation Standard Specifications.
- B. On roads designated for Shoulder Reconstruction, the Contractor shall erect "Low Shoulder" signs at the time the resurfacing operation begins. These signs shall be mounted on posts and shall remain in place until release is authorized by the Engineer.
- C. The required procedures for Shoulder Reconstruction shall be as follows:
  - a) After asphalt has sufficiently cured to prevent damage, but not to exceed 15 working days, the contractor shall re-grade the entire shoulder area along the road to dress the edge of the pavement. The contractor shall then place "Select Material-Class I or II" (Sec. 209.2.C.) in sufficient quantity to meet the lines and grades specified herein. Contractor will be required to provide this material, from off-site and haul it to the job site with all associated costs included in the bid unit price for "Shoulder Reconstruction". Failure to reach the milestone in the time listed above will result in Liquidated Damages of \$100 per calendar day per road until such work is completed.

- b) The materials shall then be thoroughly incorporated into the existing shoulder to a depth of at least 6", and then mixed until the materials are uniform and homogenous throughout. Any material, which could interfere with mixing, planting and maintaining will be considered unsuitable and must be removed by the Contractor.
  - c) Contractor shall then use the material to construct a shoulder which is level with the new pavement for a distance of at least two feet from the edge of pavement, and then tapered down to the existing ground line at a slope no steeper than 2:1. All work will be done within the County's right-of-way, and the distance from the edge of pavement to the new toe of slope will not exceed fifteen feet.
  - d) The Contractor will be responsible for the relocation of any mailboxes except permanent structures such as brick which are affected by the reconstruction work, and for saw cutting and removing affected portions of asphalt and concrete driveways. However, the Contractor will not be responsible for removing or relocating any drainage structures, or for replacing any sections of concrete driveways with concrete.
  - e) Contractor shall then roll the constructed shoulders and slope using approved equipment, with an effort sufficient to provide stabilization while allowing penetration and growth of the hydro seeding.
  - f) The entire area will then be raked either by hand or a mechanical rake, and all loose asphalt, as well as any material, which cannot be re-worked into the slopes, will be picked up and hauled off by the contractor. Contractor shall remove all shoulder dirt, which was placed on driveways.
  - g) All constructed areas shall then be hydro seeded with seed, fertilizer and wood fiber mulch, in accordance with Section 700; and maintained by the Contractor until sufficient permanent growth cover is established, including regrading and reseeding, if necessary, at no additional cost to Gwinnett County. In particular areas subject to high volumes of water runoff, the contractor will, when directed by the engineer, install erosion control netting, to help establish vegetation. Cost of this material and its installation shall be incidental to shoulder reconstruction, with no additional compensation paid. NOTE: If the timing of the shoulder reconstruction and seeding operation is such that it is not the proper season to plant permanent grass, the contractor shall plant temporary annual rye grass to obtain stability. The affected area must then be sown with permanent material, as required, as soon as possible during the next growing season at no additional cost to Gwinnett County.
- D. In addition to the above shoulder construction where there is no curb and gutter and mailboxes are set back sufficiently to allow construction, asphaltic concrete Mailbox Turnouts shall be constructed to the dimensions and specifications shown on the Mailbox Turnout details. Grading and preparation of mailbox turnout areas will be considered incidental to the overall contract, and no additional compensation will be made for this work.
- E. On roads where existing asphalt is widened to allow a 2-foot paved shoulder, in addition to the shoulder reconstruction specified herein, the preparatory work required for the paving operation will be considered incidental to Shoulder Reconstruction.
- F. All above work will be paid for as Shoulder Reconstruction-Per Shoulder Mile, and shall include, but not be limited to: all labor, materials and equipment required for preparation and dressing of all areas, removing and resetting affected mailboxes, the saw cutting, removal and disposal of affected driveway areas, hauling additional or excess material, grading and rolling shoulders, hydro seeding, erosion control, required traffic control and necessary maintenance to insure sufficient grass cover. This pay item will be measured in linear miles per side of road. This includes earth medians.
- NOTE: Asphalt Concrete materials used in construction of paved shoulders and mailbox turnouts will be paid for at the bid unit price per ton for the particular material type used.
- G. Gwinnett County reserves the right to reconstruct any shoulders using in-house labor as deemed practical.

GENERAL NOTES

1. Area involved will be graded and compacted to a depth of 2".

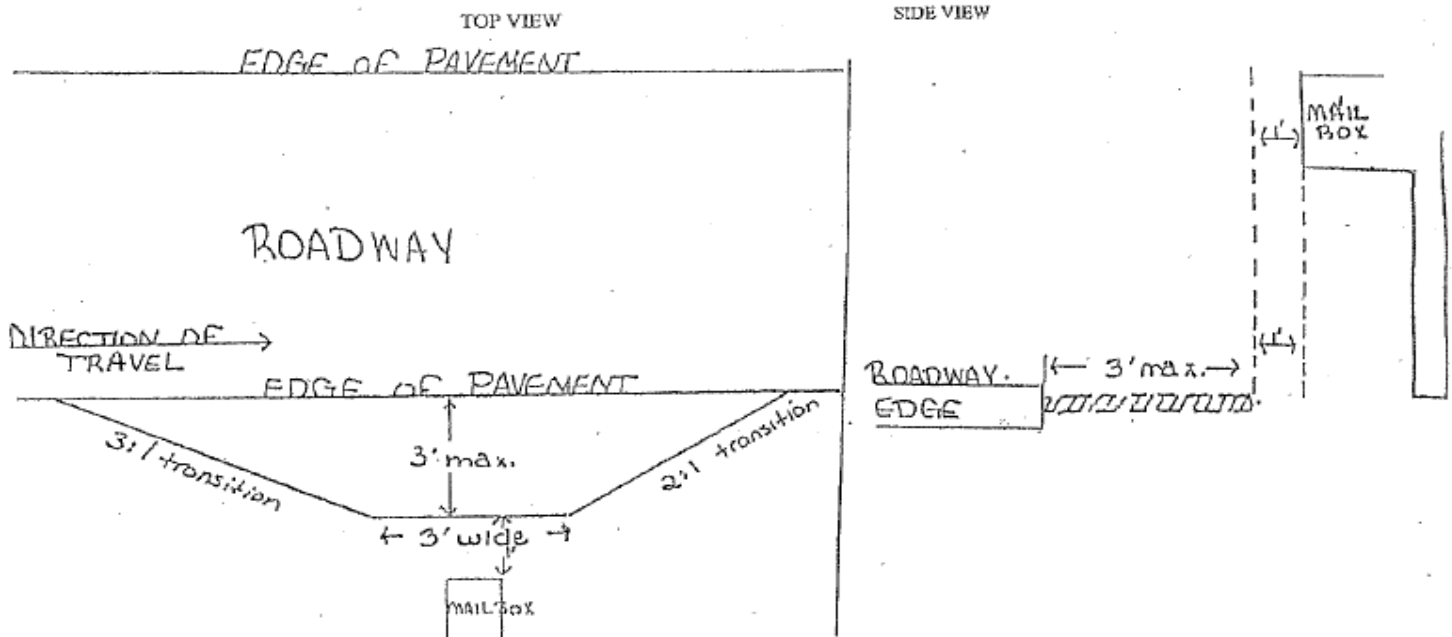
L. MAILBOX TURNOUTS

2. 2" asphaltic concrete 9.5mm will be placed and rolled.
3. Turnout will extend to within one foot of the mailbox structure, up to a maximum of three feet wide from the edge of pavement.
4. Turnout will be tapered out on a 3:1 and back to roadway on a 2:1 to allow adequate transition.
5. Any excess material will be picked up and hauled away.
6. Preparation and grading work will be considered incidental to the overall contract, and no additional compensation will be made. All asphalt work will be paid the contract price for 9.5mm per ton.

K. MILL ASPHALTIC CONCRETE PAVEMENT

1. This work shall consist of Milling and removing existing asphaltic concrete pavement prior to resurfacing, at locations designated by the Engineer, primarily to minimize material build-up above existing curb and gutter.
2. All work shall be performed in accordance with the Georgia Department of Transportation Standard Specifications, Section 432, with the exception of the required lighting system for night work, and other exceptions noted herein.
3. The County will provide the contractor with a list of roads to mill and will pre-mark the areas of removal.
4. The Contractor will give the County and public a minimum of 24 hours' notice before proceeding on patching a particular road and proper posting of such work associated with

resurfacing is required for the public.

5. Areas to be milled will be specified by the Engineer but generally 4-6 feet in width, between 1 1/2" and 3" in depth with variable lengths. If the contractor is required by the Engineer to make two milling passes on a specific road, in order to facilitate smooth traffic flow, total payment will be based on 1.5 times the number of square yards in a single pass. However, no additional payment will be made on roads where the contractor chooses to make two or more passes for equipment, productivity or other reasons.
6. The removal and disposal of the milled material will be the responsibility of the contractor and done to the satisfaction of the engineer and his time allowances.
7. The contractor shall prepare and pave the milled areas with the specified mix, as directed by the Engineer. Paving of these milled areas shall occur at the discretion of the Engineer. The contractor shall erect and maintain signs warning of uneven pavement, for the period of time between the milling and paving operations. If resurfacing is not required after milling, County forces will install all signage.
8. The above milling work shall be paid for by the square yard of Mill Asphaltic Concrete Pavement--Variable Depth, and shall include all milling, disposal and required traffic control.
9. The cleaning, tacking and paving of the milled area prior to resurfacing will be paid for at the bid unit price per ton for the particular type of asphalt used.

L. ASPHALT-RUBBER CRACK FILL

1. This work shall consist of cleaning and filling cracks in existing asphaltic concrete pavement with rubber asphalt in advance of resurfacing, at locations designated by the Engineer.
2. All work shall be performed in accordance with the Georgia Department of Transportation Standard Specifications-Section 407 for type M crack filling.
3. The County will provide the contractor with a list of roads to crack fill, and pre-mark the areas to be worked. Minimum payment length, of any particular section will be 0.1 mile, unless it is abutting an existing roadway where crack filling is being placed. On multi-lane roads crack filling will be paid 2 X for four-lane roads and 2.5X for five-lane roads based on the quoted cost for two-lane roads. Crack filling cover up time is 60 days. Payment shall include cleaning and filling of the cracks, as well as required traffic control and other items incidental to the crack-filling operation.
4. The contractor will give the County a minimum of 24 hours' notice before proceeding on crack filling a particular road.
5. This process is intended for use on roadways in advance of overlay but after milling and patching work is complete, on cracks at least 1/4" in width. It is estimated that there is approximately 20,000 linear feet of cracking to be filled per mile of roadway (2,000 lin. ft. per 0.1 mile).
6. If necessary to prevent the Asphalt-Rubber Fill from being picked up; clean, dry sand shall be spread by hand or mechanically over the filled areas. Sand shall only be applied to those areas that are tacky, and the amount shall be the least needed to prevent picking up. No extra payment for this work or material will be made.

M. HOT MIX RECYCLED ASPHALTIC CONCRETE

1. All work shall be performed in accordance with the Georgia Department of Transportation Standard Specifications-Section 402 and 820 except where otherwise noted herein:
  - a) References to "The Department" shall be taken to mean Gwinnett County or its authorized representative.
  - b) References to "The Laboratory" shall be taken to mean either the Georgia Department of Transportation's Materials Lab, or a private testing consultant firm approved by Gwinnett County.
  - c) It shall be the responsibility of the Contractor to determine the actual composition of the RAP and or GTR material and to fabricate from that the final asphaltic concrete design(s) and grade of asphalt cement necessary to meet the performance requirements of these Specifications. The contractor shall be responsible for performing daily testing on plant produced asphalt mixes as described in the 2021 Edition of the Georgia Department of Transportation Standard Specifications section 400.3.06. The contractor shall fax these results to inspecting contractor designated by Gwinnett County by noon of the day following production. Any deficiencies in the material characteristics or performance will be corrected by the Contractor, as provided for in the Specifications, at no additional cost to the County.
  - d) References to "The Plans" shall be taken to mean the contents of the contract and bid documents, or authorized written supplements to these documents.
  - e) The County will not provide a stockpile of RAP material for the contractor to draw. If RAP material removed from County roads is insufficient or out of tolerance, the contractor shall provide materials. (NOTE: See paragraph in the General Construction Guidelines Section of the Special Provisions, regarding the County's right to reclaim material).
  - f) The work performed and materials furnished, as prescribed by these specifications, will be paid for at Contract Unit Price per ton for the type of mix being placed. This payment shall be full compensation for providing all materials, hauling and necessary crushing, processing, placing, rolling, and finishing of the recycled mixture, and labor, tools, equipment, and incidentals necessary to complete the work, including hauling and stockpiling of any surplus RAP material. Any milling of existing asphaltic concrete pavements required by the County, prior to placement of the RAP material, will be performed as per the Specifications for Mill Asphaltic Concrete Pavement, and paid for at the unit price for that item.

N. DEBRIS CLEAN UP (new)

Once the contractor has been notified to clean up debris associated from patching, milling, resurfacing, or shoulder reconstruction this will be completed within five (5) working days and approved by the Engineer. If not completed within that time and the County has this done by in house forces or others the cost will be deducted from payment to the contractor. If done by an outside contractor a copy of the invoice will be provided to the resurfacing contractor. If done by in house forces a flat rate of \$250 per hour will be accessed.

O. Pavement Markings

1. This work shall consist of the re-establishment of the existing roadway pavement markings upon completion of the streets resurfacing at locations designated by the

engineer.

2. All work shall be performed in accordance with the Georgia Department of Transportation Standard Specification Section 652 Painting Traffic Stripe and Section 653 Thermoplastic Traffic Stripe except measurement and payment.
3. The Contractor shall notify the County a minimum of 24 hours before proceeding with the pavement marking work.
4. The Contractor shall place the pavement marking upon completion of the streets resurfacing and in no case later than 3 days afterward. Interim markings consisting of temporary tape will be required if not striped by the end of the working day and shall be removed prior to placement of the paint pavement markings. No pay item will be established for temporary tape. Failure to reach the milestone in the time listed above will result in Liquidated Damages of \$1,500 per calendar day per road until such work is completed.
5. Pavement marking is required for those streets that have existing roadway markings, replacing only the "long line" markings consisting of centerlines, edge lines and skip lane lines. "Short line" pavement marking will be reestablished by others with the exception of stop bars.
  - a) Pavement marking work shall follow the existing pavement marking configuration unless directed otherwise by the engineer. There will be locations where pavement marking plans will be provided by the engineer.
  - b) Re-establish existing stop bars at all resurfaced intersections and side roads with tape.
6. All the above work will be paid for as HIGH BUILD PAINT PAVEMENT MARKINGS or STANDARD THERMOPLASTIC PAVEMENT MARKINGS or WET WEATHER THERMOPLASTIC PAVEMENT MARKINGS – per lane mile and shall include but not be limited to; all labor, materials, equipment and traffic control required for the preparation and installation of the required markings. The overall length shall include both white and yellow products not as separate lengths but as one overall lane mile length of resurfaced pavement.
7. Gwinnett County reserves the right to install any pavement marking using in-house labor or contractor as deemed practical.
8. Any high build paint work shall follow the current standard specifications section 652, specifically high build standard application guidelines.
9. Any standard or wet weather thermoplastic pavement markings work shall follow the current standard specifications section 653.

P. TEMPORARY SPLOST SIGNS

1. The contractor will be required to place these on all residential streets to be resurfaced using a temporary stand. They shall be placed the day prior to resurfacing and remain in place for a minimum of two (2) days after completion. The contractor will be responsible for providing the stands, and Gwinnett County will supply the signs to the contractor once the Notice to Proceed has been issued for the contract.

2. Contractor will be responsible for keeping the signs in good condition. If the County has to continually replace the signs, a fee of \$50 per sign will be charged to the contractor for replacement.

Q. TEMPORARY SPEED HUMP REMOVAL SIGNS

1. The contractor will be required to place these on all residential streets to be resurfaced that currently have speed tables present using either a temporary stand or mounting to an existing speed hump sign post. They shall be placed the day prior to resurfacing and remain in place for a minimum of five (5) days after completion. The contractor will be responsible for providing the stands, and Gwinnett County will supply the signs to the contractor once the Notice to Proceed has been issued for the contract.
2. Contractor will be responsible for keeping the signs in good condition. If the County has to continually replace the signs, a fee of \$50 per sign will be charged to the contractor for replacement.

Please refer to the following attachments at the end of the bid document.

**FAILURE TO RETURN THIS PAGE AS PART OF YOUR BID DOCUMENT MAY RESULT IN BID BEING REJECTED.**

**BID SCHEDULE**

ITEM #	DESCRIPTION	APPROX. QTY	UNIT PRICE	TOTAL PRICE
<b>SECTION A: NORTH SECTION</b>				
1	9.5mm Recycled Asph. Conc.- including Bituminous Material, Lime and Tack Coat (SP Type II, GP 2)	500 Ton	\$	\$
2	12.5mm Recycled Asph. Conc.- including Bituminous Material, Lime and Tack Coat (GP 2)	18,000 Tons	\$	\$
3	19mm Recycled Asph. Conc.-including Bituminous Material and Tack Coat	6,000 Ton	\$	\$
4	25mm Recycled Asph. Conc.-including Bituminous Material and Tack Coat	1,000 Ton	\$	\$
5	12.5mm Recycled Asph. Conc. Patching - including Bituminous Material and Tack Coat	6,375 Ton	\$	\$
6	Recycled Asph. Conc. Leveling-including Bituminous Material, Lime and Tack Coat	4,800 Ton	\$	\$
7	Shoulder Reconstruction	18 Mile	\$	\$
8	Manhole Adjustment	15 Each	\$	\$
9	Water Valve Adjustment	70 Each	\$	\$
10	Asphalt Underlying Fabric	1,000 Sq.yds.	\$	\$
11	Mill Asphaltic Conc. Pavement - variable depth	126,450 Sq.yds.	\$	\$
12	Asphaltic Rubber Crack Fill	12 Mile	\$	\$
13	9.5mm OGFC (Class B Stone) including Bituminous Material and Tack Coat	2,000 Ton	\$	\$
14	Full Depth Reclamation (FDR)	30,000 Sq. yds	\$	\$
15	Soil-Cement Base	750 Ton	\$	\$
16	High Build Paint Pavement Markings	2 Mile	\$	\$
17	Standard Thermoplastic Pavement Markings	4 Mile	\$	\$
18	Wet Weather Thermoplastic Pavement Markings	8 Mile	\$	\$
19	Indentation Rumble Strips – Ground-in-place (continuous)	24 GLM	\$	\$
		Tons	\$	\$
<b>SECTION A TOTAL</b>				\$

Company Name \_\_\_\_\_

**FAILURE TO RETURN THIS PAGE AS PART OF YOUR BID DOCUMENT MAY RESULT IN BID BEING REJECTED.**

**BID SCHEDULE CONTINUED**

ITEM #	DESCRIPTION	APPROX. QTY		UNIT PRICE	TOTAL PRICE
<b>SECTION B: SOUTH SECTION</b>					
1	9.5mm Recycled Asph. Conc.- including Bituminous Material, Lime and Tack Coat (SP Type II, GP 2)	500	Ton	\$	\$
2	12.5mm Recycled Asph. Conc.- including Bituminous Material, Lime and Tack Coat (GP 2)	17,500	Tons	\$	\$
3	19mm Recycled Asph. Conc.-including Bituminous Material and Tack Coat	4,000	Ton	\$	\$
4	25mm Recycled Asph. Conc.-including Bituminous Material and Tack Coat	100	Ton	\$	\$
5	12.5mm Recycled Asph. Conc. Patching - including Bituminous Material and Tack Coat	7,100	Ton	\$	\$
6	Recycled Asph. Conc. Leveling-including Bituminous Material, Lime and Tack Coat	5,300	Ton	\$	\$
7	Shoulder Reconstruction	20	Mile	\$	\$
8	Manhole Adjustment	32	Each	\$	\$
9	Water Valve Adjustment	36	Each	\$	\$
10	Asphalt Underlying Fabric	1,000	Sq.yds.	\$	\$
11	Mill Asphaltic Conc. Pavement - variable depth	125,350	Sq.yds.	\$	\$
12	Asphaltic Rubber Crack Fill	13	Mile	\$	\$
13	9.5mm OGFC (Class B Stone) including Bituminous Material and Tack Coat	2,000	Ton	\$	\$
14	Full Depth Reclamation (FDR)	1,000	Sq.yds	\$	\$
15	Soil-Cement Base	200	Ton	\$	\$
16	High Build Paint Pavement Markings	2	Mile	\$	\$
17	Standard Thermoplastic Pavement Markings	10	Mile	\$	\$
18	Wet Weather Thermoplastic Pavement Markings	4	Mile	\$	\$
19	Indentation Rumble Strips – Ground-in-place (continuous)	30	GLM	\$	\$
<b>SECTION B TOTAL</b>					<b>\$</b>

Company Name \_\_\_\_\_

**FAILURE TO RETURN THIS PAGE AS PART OF YOUR BID DOCUMENT MAY RESULT IN BID BEING REJECTED.**

**BID SCHEDULE CONTINUED**

ITEM #	DESCRIPTION	APPROX. QTY		UNIT PRICE	TOTAL PRICE
<b>SECTION C: WEST SECTION</b>					
1	9.5mm Recycled Asph. Conc.- including Bituminous Material, Lime and Tack Coat (SP Type II, GP 2)	1,400	Ton	\$	\$
2	12.5mm Recycled Asph. Conc.- including Bituminous Material, Lime and Tack Coat (GP 2)	17,100	Tons	\$	\$
3	19mm Recycled Asph. Conc.-including Bituminous Material and Tack Coat	4,000	Ton	\$	\$
4	25mm Recycled Asph. Conc.-including Bituminous Material and Tack Coat	100	Ton	\$	\$
5	12.5mm Recycled Asph. Conc. Patching - including Bituminous Material and Tack Coat	6,300	Ton	\$	\$
6	Recycled Asph. Conc. Leveling-including Bituminous Material, Lime and Tack Coat	4,840	Ton	\$	\$
7	Shoulder Reconstruction	4	Mile	\$	\$
8	Manhole Adjustment	35	Each	\$	\$
9	Water Valve Adjustment	40	Each	\$	\$
10	Asphalt Underlying Fabric	1,000	Sq.yds.	\$	\$
11	Mill Asphaltic Conc. Pavement - variable depth	125,000	Sq.yds.	\$	\$
12	Asphaltic Rubber Crack Fill	9	Mile	\$	\$
13	9.5mm OGFC (Class B Stone) including Bituminous Material and Tack Coat	2,000	Ton	\$	\$
14	Full Depth Reclamation (FDR)	1,000	Sq.Yds	\$	\$
15	Soil-Cement Base	200	Ton	\$	\$
16	High Build Paint Pavement Markings	2	Mile	\$	\$
17	Standard Thermoplastic Pavement Markings	3	Mile	\$	\$
18	Wet Weather Thermoplastic Pavement Markings	7	Mile	\$	\$
19	Indentation Rumble Strips – Ground-in-place (continuous)	20	GLM	\$	\$
<b>SECTION C TOTAL</b>					\$
<b>BID TOTAL (SECTION A + SECTION B + SECTION C) DOES NOT INCLUDE OPTIONAL PRICING</b>					\$

Company Name \_\_\_\_\_

**FAILURE TO RETURN THIS PAGE AS PART OF YOUR BID DOCUMENT MAY RESULT IN BID BEING REJECTED.**

**BID SCHEDULE CONTINUED**

ITEM #	DESCRIPTION	APPROX. QTY		UNIT PRICE	TOTAL PRICE
<b>OPTIONAL PRICING:</b> The items below will not be taken into consideration when determining award, but Gwinnett County reserves the right to utilize these items if they can be provided by the awarded contractor.					
<b>SECTION A: NORTH SECTION</b>					
1	12.5mm Recycled Asph. Conc.- including GTR-Modified Bituminous Material, Lime and Tack Coat (GP 2)	100	Tons	\$	\$
	12.5mm Recycled Asph Conc including <b>Polymer</b> -Modified Bituminous Material, Lime and Tack Coat (GP2)	100	Tons	\$	\$
<b>SECTION B: SOUTH SECTION</b>					
1	12.5mm Recycled Asph. Conc.- including GTR-Modified Bituminous Material, Lime and Tack Coat (GP 2)	100	Tons	\$	\$
2	12.5mm Recycled Asph Conc including Polymer-Modified Bituminous Material, Lime and Tack Coat (GP2)	100	Tons	\$	\$
<b>SECTION C: WEST SECTION</b>					
1	12.5mm Recycled Asph. Conc.- including GTR-Modified Bituminous Material, Lime and Tack Coat (GP 2)	100	Tons	\$	\$
2	12.5mm Recycled Asph Conc including Polymer-Modified Bituminous Material, Lime and Tack Coat (GP2)	100	Tons	\$	\$

Gwinnett County requires pricing to remain firm for the duration of the initial term of the contract. Failure to hold firm pricing for the initial term of the contract will be sufficient cause for Gwinnett County to declare bid non-responsive. Contract to begin upon award.

Company Name \_\_\_\_\_

**FAILURE TO RETURN THIS PAGE AS PART OF YOUR BID DOCUMENT MAY RESULT IN BID BEING REJECTED.**

The undersigned acknowledges receipt of the following addenda, listed by number and date appearing on each:

Addendum No.	Date	Addendum No.	Date
_____	_____	_____	_____
_____	_____	_____	_____

**Termination for Cause:** The County may terminate this agreement for cause upon ten days prior written notice to the contractor of the contractor’s default in the performance of any term of this agreement. Such termination shall be without prejudice to any of the County’s rights or remedies by law.

**Termination for Convenience:** The County may terminate this agreement for its convenience at any time upon 30 days written notice to the contractor. In the event of the County’s termination of this agreement for convenience, the contractor will be paid for those services actually performed. Partially completed performance of the agreement will be compensated based upon a signed statement of completion to be submitted by the contractor, which shall itemize each element of performance.

Certification Of Non-Collusion In Bid Preparation \_\_\_\_\_  
Signature Date

**In compliance with the attached specifications, the undersigned offers and agrees, if this quote is accepted by the Board of Commissioners within ninety (90) days of the date of quote opening, to furnish any or all of the items upon which prices are quoted, at the price set opposite each item, delivered to the designated point(s) within the time specified in the quote schedule. By submission of this bid, I understand that Gwinnett County uses Electronic Payments for remittance of goods and services. Vendors should select their preferred method of electronic payment upon notice of award. For more information on electronic payments, please refer to the [Electronic Payment](#) information in the instructions to bidders.**

Legal Business Name \_\_\_\_\_  
*(If your company is an LLC, you must identify all principals to include addresses and phone numbers in your submittal)*

Complete Address \_\_\_\_\_

Does your company currently have a location within Gwinnett County? Yes  No

Representative Signature \_\_\_\_\_

Printed Name \_\_\_\_\_

Telephone Number \_\_\_\_\_ Fax Number \_\_\_\_\_

E-mail address \_\_\_\_\_

FAILURE TO RETURN THIS PAGE AS PART OF YOUR BID DOCUMENT MAY RESULT IN REJECTION OF BID.

**REFERENCES**

Gwinnett County requests a minimum of three (3) references where work of a similar size and scope has been completed.

Note: References should be customized for each project, rather than submitting the same set of references for every project bid. The references listed should be of similar size and scope of the project being bid on. Do not submit a project list in lieu of this form.

1. Company Name \_\_\_\_\_  
Brief Description of Project \_\_\_\_\_  
Completion Date \_\_\_\_\_  
Contract Amount \$ \_\_\_\_\_ Start Dates \_\_\_\_\_  
Contact Person \_\_\_\_\_ Telephone \_\_\_\_\_  
E-Mail Address \_\_\_\_\_

2. Company Name \_\_\_\_\_  
Brief Description of Project \_\_\_\_\_  
Completion Date \_\_\_\_\_  
Contract Amount \$ \_\_\_\_\_ Start Date \_\_\_\_\_  
Contact Person \_\_\_\_\_ Telephone \_\_\_\_\_  
E-Mail Address \_\_\_\_\_

3. Company Name \_\_\_\_\_  
Brief Description of Project \_\_\_\_\_  
Completion Date \_\_\_\_\_  
Contract Amount \$ \_\_\_\_\_ Start Date \_\_\_\_\_  
Contact Person \_\_\_\_\_ Telephone \_\_\_\_\_  
E-Mail Address \_\_\_\_\_

Company Name \_\_\_\_\_



## MAJOR CONSTRUCTION INSURANCE REQUIREMENTS

**Insurance:**

Contractor shall provide evidence of insurance for at least the coverage and amounts set forth below. All insurance shall be maintained in the form and with a company (or companies) satisfactory to the Gwinnett County Board of Commissioners. The Contractor and their Subcontractor's/Vendor's Certificate of Insurance shall require that the County be notified in writing thirty (30) days prior to cancellation, modification or non-renewal of any insurance policy listed on Certificate. Upon request, Contractor shall provide the County with certified copies of all required insurance policies.

**A. Minimum Coverage**

Commercial General Liability (Occurrence Form):

General Aggregate (other than Prod/Comp Ops Liability)	\$2,000,000
Products/Completed Operations Aggregate	\$2,000,000
Personal & Advertising Injury Liability	\$1,000,000
Each Occurrence	\$1,000,000

- Gwinnett County Board of Commissioners to be named as Additional Insured
- Additional Insured Endorsement CG 20 10 (edition dates of 07/04, 04/13, 12/19 or a substitute endorsement providing equivalent coverage) and CG 2037 (edition dates of 07/04, 04/13, 12/19 or a substitute endorsement providing equivalent coverage) must be provided with your Certificate of Insurance.
- Primary and Non-Contributory Endorsement to be specified in writing.
- Dedicated Limits per Project Site or Location (CG 25 03 or CG 25 04)
- Contractual Liability
- Broad Form Property Damage
- Severability of Interest
- Underground, explosion, and collapse coverage
- Personal Injury (deleting both contractual and employee exclusions)
- Incidental Medical Malpractice
- Hostile Fire Pollution Wording
- Include Waiver of Subrogation in favor of Gwinnett County Board of Commissioners
- If project or operations are within 50 ft of a railroad, Contractor is required to name the specific Railroad as an Additional Insured and provide a copy of the Additional Insured Endorsement CG2417 or its equivalent.
- In the event the General Liability insurance required by this Contract is written on a claims-made basis, Contractor warrants that any retroactive date under the policy shall precede the effective date of this Contract; and that either continuous coverage will be maintained or an extended discovery period will be exercised for a period of five (5) years or applicable statute of limitation period following completion of the work.

Automobile Liability to include:

Combined Single Limit – Each Accident	\$1,000,000
---------------------------------------	-------------

- Comprehensive form providing coverage for bodily injury, death of any person, and property damage arising out of the ownership, maintenance, and use of all owned, non-owned, leased, hired, borrowed vehicles, and any other statutorily required automobile coverage.
- Gwinnett County Board of Commissioners to be named as Additional Insured
- Additional Insured Endorsements must be provided with the Certificate of Insurance
- Coverage to include loading and unloading
- Contractual Liability

Worker's Compensation & Employer's Liability Coverage to include:

Workers Compensation	Georgia State Statutory Limits
----------------------	--------------------------------

Employers Liability

Bodily Injury by Accident – Each Accident	\$500,000
Bodily Injury by Disease – Policy Limit	\$500,000
Bodily Injury by Disease – Each Employee	\$500,000

- Waiver of Subrogation in favor of Gwinnett County Board of Commissioners

Umbrella/Excess Liability Insurance with policy limits as determined by Contract Sums (Higher limits may be required depending on the extent of contract):

Contracts Over \$5,000,000	
Each Occurrence and Aggregate Limit	\$10,000,000

- Gwinnett County Board of Commissioners to be named as Additional Insured
- Additional Insured Endorsements must be provided with the Certificate of Insurance
- Concurrency of Effective Dates with Primary
- Blanket Contractual Liability
- Draw Down Feature
- Umbrella Policy must be as broad as the primary policy.
- Coverage excess over General Liability, Business Auto Liability, and Employers Liability
- In the event the Umbrella/Excess Liability insurance required by this Contract is written on a claims-made basis, Contractor warrants that any retroactive date under the policy shall precede the effective date of this Contract; and that either continuous coverage will be maintained or an extended discovery period will be exercised for a period of five (5) years or applicable statute of limitation period following completion of the work.

Property Insurance

The Contractor is fully and solely responsible for any physical loss or damage to all tools, equipment, construction office trailers and their contents, vehicles or any other personal property utilized in the performance of the Contractor’s work. Contractor agrees to waive its rights of recovery and cause its insurers, if any, to waive their rights of subrogation against Owner and Company for any such damage or loss, however caused.

Pollution Liability Insurance. (Applies if scope of work requires the handling and/or transportation of hazardous materials, including, but not limited to, asbestos, lead, silica, contaminated soil, or any other hazardous material as defined by applicable law) then the following Pollution Liability Insurance shall meet or exceed the following minimum requirements:

Per Incident Limit	\$1,000,000
Aggregate Limit	\$2,000,000

- Limits for Bodily Injury, Property Damage, Environmental Damage or Clean-Up Costs, including coverage for Non-Owned Disposal Sites.
- For Subcontractors whose scope of work includes transportation of hazardous materials, the insurance must also include coverage for pollution conditions arising from the transportation of hazardous materials.
- Whether written on an “Occurrence” basis or on a “Claims Made” basis, coverage shall either be renewed continuously or shall provide an extended claims reporting period of five (5) years or applicable statute of limitation period following completion of the work.
- Gwinnett County Board of Commissioners shall be Additional Insureds during the term of the subcontract agreement and through all applicable statutes of limitation and repose.
- Additional Insured Endorsements must be provided with the Certificate of Insurance
- The policy shall stipulate the insurance afforded to the Additional Insureds applies as primary insurance and that any other insurance carried by the Additional Insureds will be excess only.

Riggers Liability Insurance.

If any work to be performed involves the rigging, lifting, lowering or moving of property or equipment, then those parties performing such work shall carry Rigger's Liability Insurance in an amount adequate to insure against the physical loss or damage to the property or equipment in its care

Crime or Fidelity Insurance.

Limit of Insurance \$1,000,000

- The Contractor shall maintain employee dishonesty and computer fraud coverage including, but not limited to, dishonest acts of Contractor, its employees, agents, subcontractors and anyone under Contractor's supervision or control.
- Contractor shall be liable for money, securities, or other property of the County.
- Such coverage shall include an owner coverage endorsement for County and County shall be included as a loss payee.

Cyber Liability Insurance (Applies if scope of work includes the storage or transfer of any County data or sensitive data (including but not limited to personally identifiable, health or payment card data) or the related hosting of database(s) or internet site(s)):

Limit of Insurance per Claim \$1,000,000

Aggregate Limit \$1,000,000

The Contractor shall maintain insurance coverage for network security and privacy risks, including, but not limited to, insurance for data breach or introduction of virus or malicious codes, consumer notification, whether or not required by law, forensic investigation, public relations and crisis management and credit or identity monitoring or similar remediation services, unauthorized access, failure of security information theft, damage to destruction of or alteration of electronic information, breach of privacy perils, wrongful disclosure and release of private information, collection, or other negligence in the handling of confidential information, and including coverage for related regulatory fines, defenses, and penalties allowed by law.

- B. Gwinnett County Board of Commissioners (and any applicable Authority) must be specified in writing as an Additional Insured on General Liability, Auto Liability, Umbrella Liability, Pollution, Aviation (if applicable) and Crane policies.
- C. The cancellation should provide 10 days' notice for nonpayment and 30 days' notice of cancellation.
- D. Certificate Holder should read:  
 Gwinnett County Board of Commissioners  
 75 Langley Drive  
 Lawrenceville, GA 30046-6935
- E. Insurance Company, except Worker' Compensation carrier, must have an A.M. Best Rating of A-10 or higher. Certain Workers' Comp funds may be acceptable by the approval of the Insurance Unit. European markets including those based in London and domestic surplus lines markets that operate on a non-admitted basis are exempt from this requirement provided that the contractor's broker/agent can provide financial data to establish that a market is equal to or exceeds the financial strengths associated with the A.M. Best's rating of A-10 or better.
- F. Insurance companies providing coverage should be licensed and authorized to do business by the Office of Insurance and Safety Fire Commissioner ("Insurance Commissioner"), with the exception of non-admitted carriers, in which case the broker placing coverage should be licensed by the Insurance Commissioner. All agents placing coverage should be licensed by the Insurance Commissioner, either as a resident or non-resident.
- G. Certificates of Insurance, and any subsequent renewals, must reference each corresponding bid/contract by project name and project/bid number.

- H. The Contractor shall agree to provide complete certified copies of current insurance policy(ies) or a certified letter from the insurance company(ies) if requested by the County to verify the compliance with these insurance requirements.
- I. All insurance coverage required to be provided by the Contractor will state that it is primary over any insurance program carried by the County.
- J. Contractor shall incorporate a copy of the insurance requirements as herein provided in each and every subcontract with each and every Subcontractor in any tier and shall require each and every Subcontractor of any tier to comply with all such requirements. Contractor agrees that if for any reason Subcontractor fails to procure and maintain insurance as required, all such required Insurance shall be procured and maintained by Contractor at Contractor's expense.
- K. No Contractor or Subcontractor shall commence any work of any kind under this Contract until all insurance requirements contained in this Contract have been complied with and until evidence of such compliance satisfactory to Gwinnett County as a to form and content has been filed with Gwinnett County. The ACORD Certificate of Insurance or a preapproved substitute is the required form in all cases where reference is made to a Certificate of Insurance or an approved substitute.
- L. The Contractor and its insurer(s) shall agree to waive all rights of subrogation against the County, the Board of Commissioners, its officers, officials, employees, and volunteers from losses arising from work performed by the contractor for the County.
- M. Special Form Contractors' Equipment and Contents Insurance covering owned, used, and leased equipment, tools, supplies, and contents is required to perform the services called for in the Contract. The coverage must be on a replacement cost basis. The County will be included as a Loss Payee in this coverage for County owned equipment, tools, supplies, and contents.
- N. The Contractor shall make available to the County, through its records or records of its insurer, information regarding any claim related to a County project. Any loss run information available from the Contractor or its insurer relating to a County project will be made available to the County upon its request.
- O. Compliance by the Contractor and all Subcontractors with the foregoing insurance requirements shall not relieve the Contractor and Subcontractors of liability under the Contract and any applicable law.
- P. The Contractor and all Subcontractors are to comply with the Occupational Safety and Health Act of 1970, Public Law 91-956, and any other laws that may apply to this Contract.
- Q. The Contractor shall at a minimum apply risk management practices accepted by the Contractor's industry.
- R. The Contractor shall advise the County if required limits of insurance become eroded or impaired.

**Surety Bonds (If Required)**

All of the surety requirements will stay the same except the Surety Company must have the same rating as set forth in item E above.

Gwinnett County, Georgia  
**BID BOND**

KNOW ALL MEN BY THESE PRESENTS: that

\_\_\_\_\_  
(Name of Contractor)

\_\_\_\_\_  
(Address of Contractor)

a \_\_\_\_\_  
(Corporation, Partnership or Individual)

hereinafter called Principal, and

\_\_\_\_\_  
(Name of Surety)

\_\_\_\_\_  
(Address of Surety)

a Corporation of the State of \_\_\_\_\_, and a surety authorized by law to do business in the State of Georgia, hereinafter called Surety, are held and firmly bound unto

Gwinnett County Board of Commissioners  
(Name of Obligee)

75 Langley Drive, Lawrenceville, Georgia 30046  
(Address of Obligee)

Thereinafter referred to as Obligee: in the penal sum of \_\_\_\_\_ Dollars (\$ \_\_\_\_\_) in lawful money of the United States, for the payment of which sum will and truly to be made, we bind ourselves, our heirs, executors, administrators, and successors, jointly and severally, firmly by these presents.

WHEREAS, the Principal is about to submit, or has submitted, to Gwinnett County, Georgia, a proposal for furnishing materials, labor, and equipment for: \_\_\_\_\_  
WHEREAS, the Principal desires to file this Bond in accordance with law in lieu of a certified Bidder's check otherwise required to accompany this Proposal.

NOW, THEREFORE, the conditions of this obligation are such that if the proposal be accepted, the Principal shall within ten days after receipt of notification of the acceptance, execute a Contract in accordance with the Proposal and upon the terms, conditions, and prices set forth in the form and manner required by Gwinnett County, Georgia, and execute a sufficient and satisfactory Performance Bond and Payment Bond payable to Gwinnett County, Georgia, each in the amount of 100% of the total Contract Price, in form and with security satisfactory to said Gwinnett County, Georgia, and otherwise, to be and remain in full force and virtue in law, and the Surety shall, upon failure of the Principal to comply with any or all of the foregoing requirements within the time specified above, immediately pay to Gwinnett County, Georgia, upon demand, the amount hereof in good and lawful money of the United States of America, not as a penalty, but as liquidated damages.

**Gwinnett County, Georgia**

PROVIDED, FURTHER, that Principal and Surety agree and represent that this bond is executed pursuant to and in accordance with the applicable provisions of the Official Code of Georgia Annotated, as Amended, including, but not limited to, O.C.G.A. § 36-91-1 et seq., and is intended to be and shall be constructed as a bond in compliance with the requirements thereof.

Signed, sealed and dated this \_\_\_\_\_ day of \_\_\_\_\_, A.D., 20\_\_\_\_\_.

ATTEST:

\_\_\_\_\_  
(Principal Secretary)

(SEAL)

\_\_\_\_\_  
(Principal)

By: \_\_\_\_\_

\_\_\_\_\_  
(Address)

\_\_\_\_\_  
(Witness as to Principal)

\_\_\_\_\_  
(Address)

ATTEST:

\_\_\_\_\_  
Resident or Nonresident Agent

(SEAL)

\_\_\_\_\_  
(Surety)

By: \_\_\_\_\_

(Attorney-in-Fact)

\_\_\_\_\_  
(Address)

\_\_\_\_\_  
(Witness as to Surety)

\_\_\_\_\_  
(Address)

NOTE: If Contractor is Partnership, all partners should execute Bond. Surety Companies executing Bonds must appear on the Treasury Department's most current list (Circular 570 as amended) and be authorized to transact business in the State where the Project is located.

Principal Secretary, Principal and Witness as to Principal signature lines must be signed by three different individuals. Additionally, Resident or Nonresident Agent, Witness as to Surety, and Attorney-in-fact must be signed by three different individuals.

GENERAL CONDITIONS  
To Service Provider AGREEMENT

Article

- 1 Definitions
- 2 Contract Documents
- 3 Changes and Extra Work
- 4 Personnel and Equipment
- 5 Accuracy of Work
- 6 Findings Confidential
- 7 Termination of Agreement for Cause
- 8 Termination for Convenience of the COUNTY
- 9 SERVICE PROVIDER to Cooperate with other SERVICE PROVIDERS
- 10 Indemnification
- 11 Covenant Against Contingent Fees
- 12 Insurance
- 13 Prohibited Interests
- 14 Subcontracting
- 15 Assignability
- 16 Equal Employment Opportunity
- 17 Anti-Kickback Clause
- 18 Audits and Inspectors
- 19 Ownership, Publication, Reproduction and Use
- 20 Verbal Agreement or Conversation
- 21 Independent Service provider
- 22 Notices

## 1 DEFINITIONS

Wherever used in this Agreement, whether in the singular or in the plural, the following terms shall have the following meanings:

- 1.1 COUNTY-means Gwinnett County, Georgia, a political subdivision of the State of Georgia.
- 1.2 SUPPLEMENTAL AGREEMENT-means a written order to SERVICE PROVIDER signed by COUNTY and accepted by SERVICE PROVIDER, effecting an addition, deletion or revision in the Work, or an adjustment in the Agreement Price or the Contract Time, issued after execution of this Agreement.
- 1.3 CONTRACT-means the Agreement Documents specifically identified and incorporated herein by reference in Section 2, CONTRACT DOCUMENTS.
- 1.4 AGREEMENT EXECUTION-means the date on which SERVICE PROVIDER executes and enters into an Agreement with the COUNTY to perform the Work.
- 1.5 AGREEMENT PRICE-means the total monies, adjusted in accordance with any provision herein, payable to the SERVICE PROVIDER under this Agreement.
- 1.6 CONTRACT TIME-means the period of time stated in this Agreement for the completion of the Work.
- 1.7 SERVICE PROVIDER-means the party or parties contracting directly with the COUNTY to perform Work pursuant to this Agreement.
- 1.8 DEPARTMENT- means the Director or designee of requesting department(s) named in this solicitation.
- 1.9 DRAWINGS-means collectively, all the drawings, receipt of which is acknowledged by the COUNTY, listed in this Agreement, and also such supplementary drawings as the SERVICE PROVIDER may issue from time to time in order to clarify or explain such drawing or to show details which are not shown thereon.
- 1.10 SPECIFICATIONS-means the written technical provisions including all appendices thereto, both general and specific, which form a part of the Agreement Documents.
- 1.11 SUBSERVICE PROVIDER-means any person, firm, partnership, joint venture, company, corporation, or entity having a contractual agreement with SERVICE PROVIDER or with any of its subservice providers at any tier to provide a part of the Work called for by this Agreement.
- 1.12 WORK-means any and all obligations, duties and responsibilities, including furnishing equipment, engineering, design, workmanship, labor and any other services or things necessary to the successful completion of the Project, assigned to or undertaken by SERVICE PROVIDER under this Agreement.
- 1.13 LIAISON-Representative of the COUNTY who shall act as Liaison between the County and the SERVICE PROVIDER for all matters pertaining to this Agreement, including review of SERVICE PROVIDER'S plans and work.

## 2 CONTRACT DOCUMENTS

### 2.1 LIST OF DOCUMENTS

The Agreement, any required bonds, the General Conditions, the Appendices, the Detailed Scope of Work, the Specifications, the Drawings, the Exhibits, and all Agreement Supplemental Agreements shall constitute the Agreement Documents.

### 2.2 CONFLICT AND PRECEDENCE

2.2.1 The Agreement Documents are complementary, and what is called for by one is as binding as if called for by all. In the event there are any conflicting provisions or requirements in the component parts of this Agreement, the several Agreement Documents shall take precedence in the following order:

1. Supplemental Agreements
2. Agreement
3. General Conditions
4. Detailed Scope of Work
5. Specifications
6. Drawings

## 3 CHANGES AND EXTRA WORK

The COUNTY may, at any time, request changes in the work to be performed hereunder. All such changes, including any increase or decrease in the amount of the SERVICE PROVIDER'S compensation, which are mutually agreed upon by and between the COUNTY and the SERVICE PROVIDER, shall be incorporated in written Supplemental Agreements to the Agreement.

## 4 PERSONNEL AND EQUIPMENT

The SERVICE PROVIDER represents that it has secured or will secure, at its own expense, all personnel necessary to complete this Agreement; none of whom shall be employees of, or have any contractual relationship with, the COUNTY. Primary liaison with the COUNTY will be through its designee. All of the services required hereunder will be performed by the SERVICE PROVIDER under its supervision, and all personnel engaged in the work shall be fully qualified and shall be authorized or permitted under law to perform such services.

The SERVICE PROVIDER shall employ only persons duly registered in the appropriate category in responsible charge of supervision and design of the work; and further shall employ only qualified surveyors in responsible charge of any survey work.

The SERVICE PROVIDER shall endorse all reports, contract plans, and survey data. Such endorsements shall be made by a person duly registered in the appropriate category by the Georgia State Board of Registration, being in the full employ of the SERVICE PROVIDER and responsible for the work prescribed by this Agreement.

## 5 ACCURACY OF WORK

The SERVICE PROVIDER shall be responsible for the accuracy of the work and shall promptly correct errors and omissions in its plans and specifications without additional compensations.

Acceptance of the work by the COUNTY will not relieve the SERVICE PROVIDER of the responsibility for subsequent correction of any errors and the clarification of any ambiguities.

## 6 FINDINGS CONFIDENTIAL

The SERVICE PROVIDER agrees that its conclusions and any reports are for the confidential information of the COUNTY and that it will not disclose its conclusions in whole or in part to any persons whatsoever, other than to submit its written documentation to the COUNTY, and will only discuss the same with it or its authorized representatives. Upon completion of this Agreement term, all documents, reports, maps, data and studies prepared by the SERVICE PROVIDER pursuant thereto shall become the property of the COUNTY and be delivered to the DEPARTMENT.

Articles, papers, bulletins, reports, or other materials reporting the plans, progress, analyses, or results and findings of the work conducted under this Agreement shall not be presented publicly or published without prior approval in writing of the COUNTY.

It is further agreed that if any information concerning the PROJECT, its conduct, results, or data gathered or processed should be released by the SERVICE PROVIDER without prior approval from the COUNTY, the release of same shall constitute grounds for termination of this Agreement without indemnity to the SERVICE PROVIDER, but should any such information be released by the COUNTY or by the SERVICE PROVIDER with such prior written approval, the same shall be regarded as public information and no longer subject to the restrictions of this Agreement.

## 7 TERMINATION OF AGREEMENT FOR CAUSE

If through any cause the SERVICE PROVIDER shall fail to fulfill in a timely and proper manner its obligations under this Agreement, or if the SERVICE PROVIDER shall violate any of the covenants, agreements or stipulations of this Agreement, the COUNTY shall thereupon have the right to terminate this Agreement by giving written notice to the SERVICE PROVIDER of such termination, and specifying the effective date thereof, at least ten (10) days before the effective date of such termination. Failure to maintain the scheduled level of effort as proposed and prescribed, or deviation from the aforesaid scheduler without prior approval of the COUNTY shall constitute cause for termination. In such event, all finished or unfinished documents, maps, data, studies, work papers and reports prepared by the SERVICE PROVIDER under this Agreement shall become the property of the COUNTY, and the SERVICE PROVIDER shall be entitled to receive just and equitable compensation for any satisfactory work completed on such documents, as determined by the COUNTY.

## 8 TERMINATION FOR CONVENIENCE OF THE COUNTY

The COUNTY may terminate this Agreement for its convenience at any time upon 30 days notice in writing to the SERVICE PROVIDER. If the Agreement is terminated by the COUNTY as provided in this Article 8, the SERVICE PROVIDER will be paid compensation for those services actually performed. Partially completed tasks will be compensated for based on a signed statement of completion to be submitted by the SERVICE PROVIDER which shall itemize each task element and briefly state what work has been completed and what work remains to be done.

All such expenses shall be properly documented and submitted to the COUNTY for processing and payment. The County shall be the final authority in the event of any disputes over authorized costs between the COUNTY and the Service Provider.

## 9 SERVICE PROVIDERS TO COOPERATE WITH OTHER SERVICE PROVIDERS

If the COUNTY undertakes or awards other contracts for additional related work, the SERVICE PROVIDER shall fully cooperate with such other SERVICE PROVIDERS and the COUNTY employees or appointed committee(s), and carefully fit its own work to such additional work as may be directed by the COUNTY. The SERVICE PROVIDER shall not commit or permit any act

which will interfere with the performance of work by any other SERVICE PROVIDER or COUNTY employees.

#### 10 INDEMNIFICATION

SERVICE PROVIDER agrees to protect, defend, indemnify, and hold harmless the COUNTY, its commissioners, officers, agents and employees from and against any and all liability, damages, claims, suits, liens, and judgments, for whatever nature, including claims for contribution and/or indemnification, for injuries to or death of any person or persons, or damage to the property or other rights of any person or persons to the extent arising out of and attributed to the negligent acts, errors or omissions of the SERVICE PROVIDER. SERVICE PROVIDER'S obligation to protect, defend, indemnify, and hold harmless, as set forth herein above shall include any matter arising out of any patent, trademark, copyright, or service mark, or any actual or alleged unfair competition disparagement of product or service, or other business tort of any type whatsoever, or any actual or alleged violation of trade regulations.

SERVICE PROVIDER further agrees to protect, defend, indemnify, and hold harmless the COUNTY, its commissioners, officers, agents, and employees from and against any and all claims or liability for compensation under the Worker's Compensation Act arising out of injuries sustained by any employee of the SERVICE PROVIDER.

#### 11 COVENANT AGAINST CONTINGENT FEES

The SERVICE PROVIDER warrants that no person or selling agency has been employed or retained to solicit or secure this Agreement upon an agreement or understanding for a commission, percentage, brokerage, or contingent fee, excepting bona fide employees or bona fide established commercial or selling agencies maintained by SERVICE PROVIDER for the purpose of securing business and that the SERVICE PROVIDER has not received any non-COUNTY fee related to this Agreement without the prior written consent of the COUNTY. For breach or violation of this warranty, the COUNTY shall have the right to annul this Agreement without liability or at its discretion to deduct from the Agreement Price of consideration the full amount of such commission, percentage, brokerage or contingent fee.

#### 12 INSURANCE

The SERVICE PROVIDER shall, at all times that this Agreement is in effect, cause to be maintained in force and effect an insurance policy (s) that will ensure and indemnify both GWINNETT COUNTY and SERVICE PROVIDER against liability or financial loss resulting from injuries occurring to persons or property or occurring as a result of any negligent error, act, or omission of the SERVICE PROVIDER during the term of this Agreement. The liability under such insurance policy shall be not less than as stated in the Bid Proposal.

The SERVICE PROVIDER shall provide, at all times that this Agreement is in effect, Worker's Compensation insurance in accordance with the laws of the State of Georgia.

The SERVICE PROVIDER shall provide, at all times that this Agreement is in effect, Professional Liability Insurance with a limit of not less than that as stated in the Bid Proposal.

Additionally, SERVICE PROVIDER shall provide, at all times that this Agreement is in effect, automobile liability insurance with a limit of not less than that as stated in the Bid Proposal.

The policies shall be written by a responsible company(s), to be approved by the COUNTY, and shall be non-cancelable except on thirty-(30) days' written notice to the COUNTY. Such policies shall name the COUNTY as additional insured, except for worker's compensation and

professional liability policies, and a copy of such policy or a certificate of insurance shall be filed with the Director at the time of the execution of this Agreement.

13 PROHIBITED INTERESTS

13.1 Conflict of Interest: The SERVICE PROVIDER agrees that it presently has no interest and shall acquire no interest, direct or indirect, that would conflict in any manner or degree with the performance of its services hereunder.

13.2 Interest of Public Officials: No member, officer, or employee of the COUNTY during his tenure or for one year thereafter, shall have any interest, direct or indirect, in this Agreement or the proceeds thereof.

14 SUBCONTRACTING

The SERVICE PROVIDER shall not subcontract any part of the work covered by this Agreement or permit subcontracted work to be further subcontracted without the DEPARTMENT's prior written approval of the subservice provider, except as may have been specifically stated in the SERVICE PROVIDER'S response to proposal per Exhibit A. The DEPARTMENT will not approve any subservice provider for work covered by this Agreement that has not been recommended for approval by the Department Director.

All subcontracts in the amount of \$5,000 or more shall include the provisions set forth in this Agreement.

15 ASSIGNABILITY

The SERVICE PROVIDER shall not assign or transfer whether by an assignment or novation, any of its rights, obligations, benefits, liabilities or other interest under this Agreement without the written consent of the COUNTY.

16 EQUAL EMPLOYMENT OPPORTUNITY

During the performance of this Agreement, the SERVICE PROVIDER agrees as follows: (1) the SERVICE PROVIDER will not discriminate against any employee or applicant for employment because of race, creed, color, sex or national origin; (2) the SERVICE PROVIDER will, in all solicitations or advertisements for employees placed by qualified applicants, receive consideration for employment without regard to race, creed, color, sex or national origin; (3) the SERVICE PROVIDER will cause the foregoing provisions to be inserted in all subcontracts for any work covered by the Agreement so that such provision will be binding upon each subservice provider, provided that the foregoing provision shall not apply to contracts or subcontracts for standard commercial supplies of raw materials.

17 ANTI-KICKBACK CLAUSE

Salaries of architects, draftsmen, technical engineers and engineers, and technicians performing work under this Agreement shall be paid unconditionally and not less often than once a month without deduction or rebate on any account except only such payroll deductions as are mandatory by law. The SERVICE PROVIDER hereby promises to comply with all applicable "Anti-kickback" laws, and shall insert appropriate provisions in all subcontracts covering work under this Agreement.

18 AUDITS AND INSPECTORS

At any time during normal business hours and as often as the COUNTY may deem necessary, the CONSULTANT shall make available to the COUNTY for examination all of its records with respect to all matters covered by this Agreement. It shall also permit the COUNTY to audit, examine and

make copies, excerpts or transcripts from such records of personnel, conditions of employment and other data relating to all matters covered by this Agreement.

The SERVICE PROVIDER shall maintain all books, documents, papers, accounting records and other evidence pertaining to costs incurred on the Project and used in support of its proposal and shall make such material available at all reasonable times during the period of the Agreement, and for three years from the date of final payment under the Agreement, for inspection by the COUNTY or any reviewing agencies, and copies thereof shall be furnished upon request. The SERVICE PROVIDER agrees that the provisions of this Article shall be included in any Agreements it may make with any subservice provider, assignee, or transferee.

19 OWNERSHIP, PUBLICATION, REPRODUCTION AND USE

All documents and materials prepared pursuant to this Agreement are the property of the COUNTY. The COUNTY shall have the unrestricted authority to publish, disclose, distribute, and otherwise use, in whole or in part, any reports, data, maps, or other materials prepared under this Agreement without according credit of authorship. The COUNTY shall hold harmless and indemnify the SERVICE PROVIDER against all claims arising out of such use of documents and materials without the SERVICE PROVIDER'S knowledge and consent.

20 VERBAL AGREEMENT OR CONVERSATION

No verbal agreement or conversation with any officer, agent, or employee of the COUNTY, either before, during, or after the execution of this Agreement, shall affect or modify any of the terms or obligations herein contained, nor shall such verbal agreement or conversation entitle the SERVICE PROVIDER to any additional payment whatsoever under the terms for this Agreement. All changes to this Agreement shall be in writing and appended hereto as prescribed in Article 3 above.

21 INDEPENDENT SERVICE PROVIDER

The SERVICE PROVIDER shall perform the services under this Agreement as an independent service provider and nothing contained herein shall be construed to be inconsistent with this relationship or status. Nothing in this Agreement shall be interpreted or construed to constitute the SERVICE PROVIDER or any of its agents or employees to be the agent, employee, or representative of the COUNTY.

22 NOTICES

All notices shall be in writing and delivered in person or transmitted by certified mail, postage prepaid.

**\*\*\*Gwinnett County requires that all Contracts between parties be entered into via the following documents. If any exceptions are taken to any part of this document, each must be stated in detail and submitted as part of your proposal/bid document. If no exceptions are noted, it is assumed that the party fully agrees to the contract in its entirety. Exceptions to the sample contract provided in this request for proposal will be considered in terms of responsiveness when making award. \*\*\***

**\*\*SAMPLE\*\***

**ONE-TIME SERVICE PROVIDER CONTRACT  
BL139-24, Resurfacing of Major County Roads on a Term Contract**

This **CONTRACT** made and entered into this \_\_\_\_\_ day of \_\_\_\_\_, 20\_\_ by and between Gwinnett County, Georgia (Party of the First Part, hereinafter called the "County"), and, \_\_\_\_\_(Party of the Second Part, hereinafter called the "Service Provider").

**NOW THEREFORE**, for and in consideration of the mutual promises and obligations contained herein and under the conditions hereinafter set forth, the parties do hereby agree as follows:

**1. TERM:**

This contract shall commence \_\_\_\_ (insert date) \_\_\_\_\_ and be in effect for \_\_\_\_\_ consecutive calendar days.

**2. ATTACHMENTS:**

This Contract shall consist of the Service Provider's bid/proposal and all Invitations to Bid/Proposals including all drawings, specifications, price lists, Instructions to Bidders, General Conditions, Special Provisions, Detailed Specifications, addenda, and change orders issued after execution of the Contract (hereinafter collectively referred to as the "Bid"), which are specifically incorporated herein by reference (Exhibit A). In the event of a conflict between the County's contract documents and the Service Provider's bid/proposal, the County's contract documents shall control.

**3. PERFORMANCE:**

Service Provider agrees to furnish all skill and labor of every description necessary to carry out and complete in good, firm and substantial, workmanlike manner, the work specified, in strict conformity with the Bid.

**4. PRICE:**

As full compensation for the performance of this Contract, the County shall pay the Service Provider for the actual quantity of work performed, which shall in no event exceed \$ \_\_\_\_\_. The fees for the work to be performed under this Contract shall be charged to the County in accordance with the rate schedule referenced in the Bid Proposal (Exhibit A). The County agrees to pay the Service Provider following receipt by the County of a detailed invoice, reflecting the actual work performed by the Service Provider.

**5. INDEMNIFICATION AND HOLD HARMLESS:**

Service Provider agrees to protect, defend, indemnify, and hold harmless the COUNTY, its commissioners, officers, agents and employees from and against any and all liability, damages, claims, suits, liens, and judgments, for whatever nature, including claims for contribution and/or indemnification, for injuries to or death of any person or persons, or damage to the property or other rights of any person or persons to the extent arising out of and attributed to the negligent acts, errors, or omissions of the Service Provider. Service Provider's obligation to protect, defend,

indemnify, and hold harmless, as set forth hereinabove shall include any matter arising out of any patent, trademark, copyright, or service mark, or any actual or alleged unfair competition disparagement of product or service, or other business tort of any type whatsoever, or any actual or alleged violation of trade regulations.

Service Provider further agrees to protect, defend, indemnify, and hold harmless the COUNTY, its commissioners, officers, agents, and employees from and against any and all claims or liability for compensation under the Worker's Compensation Act arising out of injuries sustained by any employee of the Service Provider.

**6. TERMINATION FOR CAUSE:**

The County may terminate this Contract for cause upon ten (10) days prior written notice to the Service Provider of the Service Provider's default in the performance of any term of this Contract. Such termination shall be without prejudice to any of the County's rights or remedies provided by law.

**7. TERMINATION FOR CONVENIENCE:**

The County may terminate this Contract for its convenience at any time upon 30 days written notice to the Service Provider. In the event of the County's termination of this Contract for convenience, the Service Provider will be paid for those services actually performed. Partially completed performance of the Contract will be compensated based upon a signed statement of completion to be submitted by the Service Provider who shall itemize each element of performance.

**8. CONTRACT NOT TO DISCRIMINATE:**

During the performance of this Contract, the Service Provider will not discriminate against any employee or applicant for employment because of race, creed, color, sex, national origin, age, or disability which does not preclude the applicant or employee from performing the essential functions of the position. The Service Provider will also, in all solicitations or advertisements for employees placed by qualified applicants, consider the same without regard to race, creed, color, sex, national origin, age, or disability, which does not preclude the applicant from performing the essential functions of the job. The Service Provider will cause the foregoing provisions to be inserted in all subcontracts for any work covered by this Contract so that such provision will be binding upon each subservice provider, providing that the foregoing provisions shall not apply to contracts or subservice providers for standard commercial supplies of raw materials.

**9. ASSIGNMENT:**

The Service Provider shall not sublet, assign, transfer, pledge, convey, sell or otherwise dispose of the whole or any part of this Contract or his right, title, or interest therein to any person, firm, or corporation without the previous consent of the County in writing.

**10. WAIVER:**

A waiver by either party of any breach of any provision, term, covenant, or condition of this Contract shall not be deemed a waiver of any subsequent breach of the same or any other provision, term, covenant, or condition.

**11. SEVERABILITY:**

The parties agree that each of the provisions included in this Contract is separate, distinct and severable from the other and remaining provisions of this Contract, and that the invalidity of any Contract provision shall not affect the validity of any other provision or provisions of this Contract.

**12. GOVERNING LAW:**

The parties agree that this Contract shall be governed and construed in accordance with the laws of the State of Georgia. This Contract has been signed in Gwinnett County, Georgia.

**13. MERGER CLAUSE:**

The parties agree that the terms of this Contract include the entire Contract between the parties, and as such, shall exclusively bind the parties. No other representations, either oral or written, may be used to contradict the terms of this Contract.

[Signatures Next Page]

**IN WITNESS WHEREOF**, the parties hereto, acting through their duly authorized agents, have caused this **CONTRACT** to be signed, sealed and delivered.

WINNETT COUNTY, GEORGIA

By: \_\_\_\_\_

Nicole L. Hendrickson, Chairwoman  
Gwinnett County Board of  
Commissioners

ATTEST:

\_\_\_\_\_  
Signature

Tina King, County Clerk  
Board of Commissioners

APPROVED AS TO FORM:

\_\_\_\_\_  
Signature  
Gwinnett County Staff Attorney

SERVICE PROVIDER:\_\_\_\_\_

BY:\_\_\_\_\_  
Signature

\_\_\_\_\_  
Print Name

\_\_\_\_\_  
Title

ATTEST:

\_\_\_\_\_  
Signature

\_\_\_\_\_  
Print Name  
Corporate Secretary  
(Seal)



### CODE OF ETHICS AFFIDAVIT

PLEASE RETURN THIS FORM COMPLETED WITH YOUR SUBMITTAL. SUBMITTED FORMS ARE REQUIRED PRIOR TO EVALUATION.

In accordance with Section 54-33 of the Gwinnett County Code of Ordinances the undersigned bidder/proposer makes the following full and complete disclosure under oath, to the best of their knowledge, of the name(s) of all elected officials whom it employs or who have a direct or indirect pecuniary interest in or with the vendor, its affiliates or its subcontractors:

1. \_\_\_\_\_

Company Submitting Bid/Proposal

2. Please select one of the following:

- No information to disclose *(complete only section 4 below)*
- Disclosed information below *(complete section 3 & section 4 below)*

3. If additional space is required, please attach list: \_

\_\_\_\_\_  
Gwinnett County Elected Official Name

\_\_\_\_\_  
Gwinnett County Elected Official Name

\_\_\_\_\_  
Gwinnett County Elected Official Name

\_\_\_\_\_  
Gwinnett County Elected Official Name

4. BY: \_\_\_\_\_  
Authorized Officer or Agent Signature

Sworn to and subscribed before me this

\_\_\_\_\_  
Printed Name of Authorized Officer or Agent

\_\_\_\_\_ day of \_\_\_\_\_, 20\_\_\_\_

\_\_\_\_\_  
Title of Authorized Officer or Agent of Contractor

\_\_\_\_\_  
Notary Public

(seal)

Note: See Gwinnett County Code of Ethics Ordinance EO2011, Sec. 54-33. The ordinance will be available to view in its' entirety at **GwinnettCounty.com**



**CONTRACTOR AFFIDAVIT AND AGREEMENT  
(THIS FORM SHOULD BE FULLY COMPLETED AND RETURNED WITH YOUR SUBMITTAL)**

By executing this affidavit, the undersigned contractor verifies its compliance with The Illegal Immigration Reform Enhancements for 2013, stating affirmatively that the individual, firm, or corporation which is contracting with the Gwinnett County Board of Commissioners has registered with and is participating in a federal work authorization program\* [any of the electronic verification of work authorization programs operated by the United States Department of Homeland Security or any equivalent federal work authorization program operated by the United States Department of Homeland Security] to verify information of newly hired employees, pursuant to the Immigration Reform and Control Act, in accordance with the applicability provisions and deadlines established therein.

The undersigned further agrees that, should it employ or contract with any subcontractor(s) in connection with the physical performance of services or the performance of labor pursuant to this contract with the Gwinnett County Board of Commissioners, contractor will secure from such subcontractor(s) similar verification of compliance with the Illegal Immigration Reform and Enforcement Act on the Subcontractor Affidavit provided in Rule 300-10-01-.08 or a substantially similar form. Contractor further agrees to maintain records of such compliance and provide a copy of each such verification to the Gwinnett County Board of Commissioners at the time the subcontractor(s) is retained to perform such service.

\_\_\_\_\_  
E-Verify \* User Identification Number

\_\_\_\_\_  
Date Registered

\_\_\_\_\_  
Legal Company Name

\_\_\_\_\_  
Street Address

\_\_\_\_\_  
City/State/Zip Code

BY: \_\_\_\_\_  
Authorized Officer or Agent  
(Contractor Signature)

\_\_\_\_\_  
Date

\_\_\_\_\_  
Title of Authorized Officer or Agent of Contractor

\_\_\_\_\_  
Printed Name of Authorized Officer or Agent

SUBSCRIBED AND SWORN BEFORE ME ON THIS THE  
\_\_\_\_ DAY OF \_\_\_\_\_, 20\_\_\_\_

\_\_\_\_\_  
Notary Public  
My Commission Expires: \_\_\_\_\_

**For Gwinnett County Use Only:**  
Document ID # \_\_\_\_\_  
Issue Date: \_\_\_\_\_  
Initials: \_\_\_\_\_

\* As of the effective date of O.C.G.A. 13-10-91, the applicable federal work authorization program is "E-Verify" operated by the U.S. Citizenship and Immigration Services Bureau of the U.S. Department of Homeland Security, in conjunction with the Social Security Administration (SSA).

BOND #

**PAYMENT BOND**

KNOW ALL MEN BY THESE PRESENTS: that

\_\_\_\_\_  
(Name of Contractor)

\_\_\_\_\_  
(Address of Contractor)

a \_\_\_\_\_  
(Corporation, Partnership or Individual)

hereinafter called Principal, and

\_\_\_\_\_  
(Name of Surety)

\_\_\_\_\_  
(Address of Surety)

a Corporation of the State of \_\_\_\_\_, and a surety authorized by law to do business in the State of Georgia, hereinafter called Surety, are held and firmly bound unto

Gwinnett County Board of Commissioners  
(Name of Obligee)

75 Langley Drive, Lawrenceville, Georgia 30046  
(Address of Obligee)

hereinafter called Obligee;

for the use and protection of all subcontractors and all persons supplying labor, services, skill, tools, machinery, materials and/or equipment in the prosecution of the work provided for in the contract hereinafter referred to in the full and just sum of \_\_\_\_\_

\_\_\_\_\_  
Dollars

(\$ \_\_\_\_\_) in lawful money of the United States, for the payment of which sum, will and truly to be made, the Principal and Surety bind themselves, their, and each of their heirs, executors, administrators, successors and assigns, jointly and severally, firmly by these presents.

The condition of this obligation is such, as whereas the Principal entered into a certain contract, hereto attached, with the Obligee.

NOW, THEREFORE THE CONDITION OF THIS OBLIGATION IS SUCH, that if the Principal shall well, truly, and faithfully perform said Contract according to its terms, covenants, and conditions, and shall promptly pay all persons furnishing labor, materials services, skill, tools, machinery and/or equipment for use in the performance of said Contract, then this obligation shall be void; otherwise it shall remain in full force and effect.

ALL persons who have furnished labor, materials, services, skill, tools, machinery and/or equipment for use in the performance of said Contract shall have a direct right of action on this Bond, provided payment has

not been made in full within ninety (90) days after the last day on which labor was performed, materials, services, skill, tools, machinery, and equipment furnished or the subcontract completed.

PROVIDED FURTHER, that said Surety to this Bond, for value received, hereby stipulates and agrees that no change, extension of time, alterations, or additions to the terms of the Contract or to the Work to be performed thereunder shall in any way affect its obligation on this bond, and it does hereby waive notice of any such change, extension of time, alterations, or additions to the terms of the Contract or to the work to be performed thereunder.

PROVIDED, HOWEVER, that no suit or action shall be commenced hereunder by any person furnishing labor, materials, services, skill, tools, machinery, and/or equipment having a direct contractual relationship with a subcontractor, but no contractual relationship express or implied with the Principal:

Unless such person shall have given notice to the Principal within ninety (90) days after such person did, or performed the last of the work or labor, or furnished the last of the materials, services, skill, tools, machinery and/or equipment for which claim is made, stating with substantial accuracy the amount claimed and the name of the party to whom the materials, services, skill, tools, machinery and/or equipment were furnished, or for whom the work or labor was done or performed. Such a notice shall be served by mailing the same by registered mail, postage prepaid, in an envelope addressed to the Principal, at any place where an office is regularly maintained for the transaction of business, or served in any manner in which legal process may be served in the State in which the aforesaid project is located, save that such service need not be made by a public officer, and a copy of such notice shall be delivered to the Obligee, to the person and at the address provided for in the Contract, within five (5) days of the mailing of the notice to the Principal.

PROVIDED, FURTHER, that any suit under this bond must be instituted before the expiration of one (1) year after the acceptance of the public works covered by the Contract by the proper authorities.

PROVIDED, FURTHER, that Principal and Surety agree and represent that this bond is executed pursuant to and in accordance with the applicable provisions of the Official Code of Georgia Annotated, as Amended, including, but not limited to, O.C.G.A. § 36-91-1 et seq., and is intended to be and shall be construed as a bond in compliance with the requirements thereof.

[Signatures Next Page]

ATTEST:

\_\_\_\_\_  
(Principal Secretary)

(SEAL)

\_\_\_\_\_  
(Witness as to Principal)

\_\_\_\_\_  
(Address)

\_\_\_\_\_

ATTEST:

\_\_\_\_\_  
Resident or Nonresident Agent

(SEAL)

\_\_\_\_\_  
(Witness as to Surety)

\_\_\_\_\_  
(Address)

\_\_\_\_\_

\_\_\_\_\_  
(Principal)

By: \_\_\_\_\_

\_\_\_\_\_  
(Address)

\_\_\_\_\_  
(Surety)

By: \_\_\_\_\_  
(Attorney-in-Fact)

\_\_\_\_\_  
(Address)

\_\_\_\_\_

**BONDING AGENT CONTACT INFO**

Print Name\_\_\_\_\_

Company Name\_\_\_\_\_

E-Mail\_\_\_\_\_

Phone\_\_\_\_\_

**NOTE: If Contractor is Partnership, all partners should execute Bond. Surety Companies executing Bonds must appear on the Treasury Department's most current list (Circular 570 as amended) and be authorized to transact business in the State where the Project is located. Principal Secretary, Principal and Witness as to Principal signature lines must be signed by three different individuals. Additionally, Resident or Nonresident Agent, Witness as to Surety, and Attorney-in-fact must be signed by three different individuals.**

**BOND #**

**PERFORMANCE BOND**

KNOW ALL MEN BY THESE PRESENTS: that

\_\_\_\_\_  
(Name of Contractor)

\_\_\_\_\_  
(Address of Contractor)

a \_\_\_\_\_  
\_\_\_\_\_(Corporation, Partnership or Individual)

hereinafter called Principal, and

\_\_\_\_\_  
(Name of Surety)

\_\_\_\_\_  
(Address of Surety)

a Corporation of the State of \_\_\_\_\_, and a surety authorized by law to do business in the State of Georgia, hereinafter called Surety, are held and firmly bound unto

Gwinnett County Board of Commissioners  
(Name of Obligee)

75 Langley Drive, Lawrenceville, Georgia 30046  
(Address of Obligee)

hereinafter referred to as Obligee, are held and firmly bound unto said Obligee and all persons doing work or furnishing skill, tools, machinery, supplies, or material under or for the purpose of the Contract hereinafter referred to, in the penal sum of \_\_\_\_\_

\_\_\_\_\_  
Dollars

(\$ \_\_\_\_\_) in lawful money of the United States, for the payment of which sum will and truly to be made, we bind ourselves, our heirs, executors, administrators and successors, jointly and severally, firmly by these presents.

The condition of this obligation is such, as whereas the Principal entered into a certain contract, hereto attached, with the Obligee.

NOW, THEREFORE THE CONDITION OF THIS OBLIGATION IS SUCH, that if the Principal shall well, truly, fully and faithfully perform said contract according to its terms, covenants, conditions, and agreements of said contract during the original term of said contract and any extensions thereof that may be granted by the Obligee, with or without notice to the Surety, and during the life of any guaranty required under the contract, and shall also well and truly perform and fulfill all the undertakings, covenants, terms, conditions and agreement of any and all duly authorized modifications of said contract that may hereafter be made, then this obligation shall be void, otherwise to remain in full force and effect.

PROVIDED FURTHER, that said Surety to this Bond, for value received, hereby stipulates and agrees that no change, extension of time, alterations, or additions to the terms of the Contract or to the Work to be performed thereunder shall in any way affect its obligation on this bond, and it does hereby waive notice of any such change, extension of time, alterations, or additions to the terms of the Contract or to the work to be performed thereunder.

PROVIDED, FURTHER, that Principal and Surety agree and represent that this bond is executed pursuant to and in accordance with the applicable provisions of the Official Code of Georgia Annotated, as Amended, including, but not limited to, O.C.G.A. § 36-91-1 et seq., and is intended to be and shall be construed as a bond in compliance with the requirements thereof.

(Signatures Next Page)

ATTEST:

\_\_\_\_\_  
(Principal Secretary)

(SEAL) \_\_\_\_\_

\_\_\_\_\_  
(Witness as to Principal)

\_\_\_\_\_  
(Address)

\_\_\_\_\_

\_\_\_\_\_  
(Principal)

By: \_\_\_\_\_

\_\_\_\_\_  
(Address)

\_\_\_\_\_  
(Surety)

By: \_\_\_\_\_  
(Attorney-in-Fact)

ATTEST:

\_\_\_\_\_  
Resident or Nonresident Agent

(SEAL)

\_\_\_\_\_  
(Witness as to Surety)

\_\_\_\_\_  
(Address)

\_\_\_\_\_

\_\_\_\_\_  
(Address)

\_\_\_\_\_

**BONDING AGENT CONTACT INFO**

Print Name \_\_\_\_\_

Company Name \_\_\_\_\_

E-Mail \_\_\_\_\_

Phone \_\_\_\_\_

NOTE: If Contractor is Partnership, all partners should execute Bond. Surety Companies executing Bonds must appear on the Treasury Department's most current list (Circular 570 as amended) and be authorized to transact business in the State where the Project is located.

**Principal Secretary, Principal and Witness as to Principal signature lines must be signed by three different individuals. Additionally, Resident or Nonresident Agent, Witness as to Surety, and Attorney-in-fact must be signed by three different individuals.**

**GWINNETT COUNTY**  
**DEPARTMENT OF FINANCIAL SERVICES – PURCHASING DIVISION**  
GENERAL INSTRUCTIONS FOR VENDORS, TERMS AND CONDITIONS

**\*\*\*ATTENTION\*\*\***

FAILURE TO RETURN THE FOLLOWING DOCUMENTS MAY RESULT IN SUBMITTAL BEING DEEMED NON-RESPONSIVE AND AUTOMATIC REJECTION. THE COUNTY SHALL BE THE SOLE DETERMINANT OF TECHNICALITY VS. NON-RESPONSIVE SUBMITTAL:

1. FAILURE TO USE COUNTY FEE SCHEDULE.
2. FAILURE TO RETURN OR ACKNOWLEDGE APPLICABLE COMPLIANCE/SPECIFICATION SHEETS.
3. FAILURE TO RETURN OR ACKNOWLEDGE APPLICABLE ADDENDA.
4. FAILURE TO PROVIDE INFORMATION ON ALTERNATES OR EQUIVALENTS.
5. FAILURE TO PROVIDE BID BOND, WHEN REQUIRED, WILL RESULT IN SUBMITTAL BEING DEEMED NON-RESPONSIVE AND AUTOMATIC REJECTION. BID BONDS ARE NOT REQUIRED ON ALL SOLICITATIONS. BOND REQUIREMENTS ARE CLEARLY STATED ON THE INVITATION PAGE. IF CLARIFICATION IS NEEDED, CONTACT THE PURCHASING ASSOCIATE LISTED IN THE INVITATION. **IF BONDS ARE REQUIRED, FORMS WILL BE PROVIDED IN THIS SOLICITATION DOCUMENT.**
6. FAILURE TO PROVIDE CONTRACTOR AFFIDAVIT AND AGREEMENT, WHEN REQUIRED, MAY RESULT IN SUBMITTAL BEING DEEMED NON-RESPONSIVE AND REJECTED. THE CONTRACTOR AFFIDAVIT AND AGREEMENT IS NOT REQUIRED ON ALL SOLICITATIONS. IF CLARIFICATION IS NEEDED, CONTACT THE PURCHASING ASSOCIATE LISTED IN THE INVITATION.
7. FAILURE TO PROVIDE AN ETHICS AFFIDAVIT WHEN REQUIRED, MAY RESULT IN SUBMITTAL BEING DEEMED NON-RESPONSIVE AND REJECTED. THE ETHICS AFFIDAVIT IS REQUIRED ON ALL FORMAL SOLICITATIONS OVER \$100,000.00. IF CLARIFICATION IS NEEDED, CONTACT THE PURCHASING ASSOCIATE LISTED IN THE INVITATION.

**I. PREPARATION OF SUBMITTAL**

- A. Each vendor shall examine the drawings, specifications, schedule, and all instructions. Failure to do so will be at the vendor's risk, as the vendor will be held accountable for their submittal.
- B. Each vendor shall furnish all information required by the solicitation form or document. Each vendor shall sign the submittal and print or type his or her name on the fee schedule. The person signing the submittal should initial erasures or other changes. An authorized agent of the vendor must sign the submittal.
- C. Fee schedule pricing should have only two decimal places unless otherwise stated. In the event of a calculation error in total price, the unit pricing prevails.
- D. Except for solicitations for the sale of real property, individuals, firms, and businesses seeking an award of a Gwinnett County contract may not initiate or continue any verbal or written communications regarding a solicitation with any County officer, elected official, employee, or other County representative other than the Purchasing Associate named in the solicitation between the date of the issuance of the solicitation and the date of the final award. The Purchasing Director will review violations. If determined that such communication has compromised the competitive process, the offer submitted by the individual, firm or business may be disqualified from consideration for award. Solicitations for the sale of real property may allow for verbal or written communications with the appropriate Gwinnett County representative.
- E. Sample contracts (if pertinent) are attached. These do NOT have to be filled out with the submittal but are contained for informational purposes only. If awarded, the successful vendor(s) will be required to execute these documents prior to County execution.
- F. Effective July 1, 2013 and in accordance with the Georgia Illegal Immigration Reform Enhancements for 2013, an original signed, notarized and fully completed Contractor Affidavit and Agreement should be included with vendor's submittal, if the solicitation is for the physical performance of services for all labor or service contract(s) that exceed \$2,499.99 (except for services performed by an individual who is licensed pursuant to Title 26, Title 43, or the State Bar of Georgia). Failure to provide the Contractor Affidavit and Agreement with your submittal may result in being deemed non-responsive and automatic rejection.

**II. DELIVERY**

- A. Each vendor should state time of proposed delivery of goods or services.
- B. Words such as "immediate," "as soon as possible," etc. should not be used. The known earliest date or the minimum number of calendar days required after receipt of order (delivery A.R.O.) should be stated. If calendar days are used, include Saturday, Sunday, and holidays in the number.

**III. EXPLANATION TO VENDORS**

Any explanation desired by a vendor regarding the meaning or interpretation of the solicitation, drawings, specifications, etc. must be requested by the question cutoff deadline stated in the

solicitation for a reply to reach all vendors before the deadline of the solicitation. Any information given to a prospective vendor concerning a solicitation will be furnished to all prospective vendors as an addendum to the solicitation if such information is necessary or if the lack of such information would be prejudicial to uninformed vendors. The written solicitation documents supersede any verbal or written communications between the parties. Receipt of addenda should be acknowledged in the submittal. **It is the vendor's responsibility to ensure they have all applicable addenda prior to their submittal.** This may be accomplished by contacting the assigned Purchasing Associate prior to the submittal or visiting the Gwinnett County website.

#### IV. SUBMISSION OF FORMAL OFFERS/SUBMITTALS

- A. Formal bid and proposal submittals shall be enclosed in a sealed package or envelope, addressed to the Gwinnett County Purchasing Division with the name of the vendor, the date and hour of opening and the solicitation number on the face of the package or envelope. Facsimile or emailed submittals will not be considered. Any addenda should be enclosed in the sealed envelopes as well.
- B. ADD/DEDUCT: Add or deduct amounts indicated on the outside of the envelope are allowed and will be applied to the lump sum amount. Amount shall be clearly stated and should be initialed by an authorized representative.
- C. Samples of items, when required, must be submitted within the time specified and, unless otherwise specified by the County, at no expense to the County. Unless otherwise specified, samples will be returned at the vendor's request and expense, if items are not destroyed by testing.
- D. Items offered must meet required specifications and must be of a quality that will adequately serve the use and purpose for which intended.
- E. Full identification of each item submitted, including brand name, model, catalog number, etc. must be furnished to identify exactly what the vendor is offering. Manufacturer's literature may be furnished but vendor should not submit excessive marketing material.
- F. The vendor must certify that items to be furnished are new and that the quality has not deteriorated to impair its usefulness.
- G. Unsigned submittals will not be considered except in cases where it is enclosed with other documents that have been signed. The County will determine acceptability in these cases.
- H. Gwinnett County is exempt from federal excise tax and Georgia sales tax regarding goods and services purchased directly by Gwinnett County. Vendors are responsible for federal excise tax and sales tax, including taxes for materials incorporated in county construction projects. Vendors should contact the State of Georgia Sales Tax Division for additional information. Agreements were there is a cost-plus mark-up, mark-up will not be paid on taxes.

- I. Information submitted by a vendor in the solicitation process shall be subject to disclosure after the public opening in accordance with the Georgia Open Records Act.

**V. WITHDRAWAL DUE TO ERRORS**

Vendors must give Gwinnett County Purchasing Division written notice within two (2) business days of completion of the opening stating that they wish to withdraw their submittal without penalty for an obvious clerical or calculation error. Submittal may be withdrawn from consideration if the price was substantially lower than the other submittals due solely to a mistake therein, provided pricing was submitted in good faith, and the mistake was a clerical mistake as opposed to a judgment mistake and was due to an unintentional arithmetic error or an unintentional omission of a quantity of work, labor or material made directly in the compilation of the submittal. The unintentional arithmetic error or omission can be clearly proven through inspection of the original work papers, documents, and materials used in preparing the submittal sought to be withdrawn. The vendor's original work papers shall be the sole acceptable evidence of error and mistake if a vendor elects to withdraw their submittal. If a quote or bid submittal is withdrawn under the authority of this provision, the lowest remaining responsive offer shall be deemed to be low bid.

No vendor who is permitted to withdraw their submittal shall, for compensation, supply any material or labor or perform any subcontract or other work agreement for the person or firm to whom the contract is awarded or otherwise benefit, directly or indirectly, from the performance of the project for which the withdrawn bid or proposal was submitted.

Vendors who fail to request withdrawal by the required forty-eight (48) hours may automatically forfeit bid bond if a bond was required. Bid may not be withdrawn otherwise.

Withdrawal is not automatically granted and will be allowed solely at Gwinnett County's discretion.

**VI. TESTING AND INSPECTION**

Since tests may require several days for completion, the County reserves the right to use a portion of any supplies before the results of the tests are determined. Cost of inspections and tests of any item that fails to meet the specifications, shall be borne by the vendor.

**VII. F.O.B. POINT**

Unless otherwise stated in the request for invitation and any resulting contract, or unless qualified by the vendor, items shall be shipped F.O.B. Destination, Freight Prepaid and Allowed. The seller shall retain title for the risk of transportation, including the filing for loss or damages. The invoice covering the items is not payable until items are delivered and the contract of carriage has been completed. Unless the F.O.B. clause states otherwise, the seller assumes transportation and related charges either by payment or allowance.

**VIII. PATENT INDEMNITY**

The vendor guarantees to hold the County, its agents, officers, or employees harmless from liability of any nature or kind for use of any copyrighted or uncopied composition, secret

process, patented or unpatented invention, articles or appliances furnished or used in the performance of the contract, for which the vendor is not the patentee, assignee, or licensee.

**IX. BID BONDS AND PAYMENT AND PERFORMANCE BONDS (IF REQUIRED, FORMS WILL BE PROVIDED IN THIS DOCUMENT)**

A five percent (5%) bid bond, a one hundred percent (100%) performance bond, and a one hundred percent (100%) payment bond must be furnished to Gwinnett County for any solicitation as required in the solicitation package or document. **Failure to submit a bid bond with the proper rating will result in submittal being deemed non-responsive.** Bonding company must be authorized to do business in Georgia by the Georgia Insurance Commission, listed in the Department of the Treasury's publication of companies holding certificates of authority as acceptable surety on Federal bonds and as acceptable reinsuring companies, and have an A.M. Best rating as stated in the insurance requirement of the solicitation. **The bid bond, payment bond, and performance bond must have the proper A.M. Best rating as stated in the solicitation document.**

**X. DISCOUNTS**

- A. Time payment discounts may be considered in arriving at net prices and in award of solicitations. Offers of discounts for payment within ten (10) days following the end of the month are preferred.
- B. In connection with any discount offered, time will be computed from the date of delivery and acceptance at destination, or from the date correct invoice or voucher is received, whichever is the later date. Payment is deemed to be made for the purpose of earning the discount on the date of the County check.

**XI. AWARD**

- A. Award will be made to either the highest scoring firm (for proposals) or the lowest responsive and responsible vendor (for quotes/bids). The quality of the articles to be supplied, their conformity with the specifications, their suitability to the requirements of the County, and the delivery terms will be taken into consideration in making the award. The County may make such investigations as it deems necessary to determine the ability of the vendor to perform, and the vendor shall furnish to the County all such information and data for this purpose as the County may request. The County reserves the right to reject any submittal if the evidence submitted by, or investigation of such vendor fails to satisfy the County that such vendor is properly qualified to carry out the obligations of the contract.
- B. The County reserves the right to reject or accept any or all offers and to waive technicalities, informalities and minor irregularities in the submittals received.
- C. The County reserves the right to make an award as deemed in its best interest, which may include awarding to a single vendor or multiple vendors; or to award the whole solicitation agreement, only part of the agreement, or none of the agreement, based on its sole discretion of its best interest.
- D. In the event of proposal scores rounded to the nearest whole number result in a tie score, the award

will be based on lowest cost.

- E. If proposal negotiations with the highest ranked firm are unsuccessful, the County may then negotiate with the second ranked firm and so on until a satisfactory agreement has been reached.

## **XII. DELIVERY FAILURES**

Failure of a vendor to deliver within the time specified or within reasonable time as interpreted by the Purchasing Director, or failure to make replacement of rejected articles/services when so requested, immediately or as directed by the Purchasing Director, shall constitute authority for the Purchasing Director to purchase in the open market articles/services of comparable grade to replace the articles/services rejected or not delivered. On all such purchases, the vendor shall reimburse the County within a reasonable time specified by the Purchasing Director for any expense incurred in excess of the contract prices, or the County shall have the right to deduct such amount from monies owed the defaulting vendor. Alternatively, the County may penalize the vendor one percent (1%) per day for a period of up to ten (10) days for each day that delivery or replacement is late. Should public necessity demand it, the County reserves the right to use or consume articles/services delivered which are substandard in quality, subject to an adjustment in price to be determined by the Purchasing Director.

## **XIII. COUNTY FURNISHED PROPERTY**

No material, labor or facilities will be furnished by the County unless so provided in the solicitation package.

## **XIV. REJECTION OF SUBMITTALS**

Failure to observe any of the instructions or conditions in this solicitation package may constitute grounds for rejection.

## **XV. CONTRACT**

Each submittal is received with the understanding that the acceptance in writing by the County of the offer to furnish any or all the commodities or services described therein shall constitute a contract between the vendor and the County which shall bind the vendor on his part to furnish and deliver the articles quoted at the prices stated in accordance with the conditions of said accepted submittal. The County, on its part, may order from such vendor, except for cause beyond reasonable control, and to pay for, at the agreed prices, all articles specified and delivered.

Upon receipt of a solicitation package containing a Gwinnett County "Sample Contract" as part of the requirements, it is understood that the vendor has reviewed the documents with the understanding that Gwinnett County requires that all agreements between the parties must be entered into via this document. If any exceptions are taken to any part, each must be stated in detail and submitted as part of the vendor's submittal. If no exceptions are stated, it is assumed that the vendor fully agrees to the provisions contained in the "Sample Contract" in its entirety.

Any Consultant as defined in O.C.G.A. §36-80-28 that is engaged to develop or draft specifications/requirements or serve in a consultative role during the procurement process for any County procurement method, by entering into such an arrangement or executing a contract,

the consultant agrees to abide by the current state law and: 1) Avoid any appearance of impropriety and shall follow all policies and procedures of the County, 2) Disclose to the County any material transaction or relationship pursuant to §36-80-28, that is considered a conflict of interest, any involvement in litigation or other dispute, relationship, or financial interest not disclosed in the ethics affidavit, and 3) Acknowledge that any violation or threatened violation of the agreement may cause irreparable injury to the County, entitling the County to seek injunctive relief in addition to all other legal remedies.

When the vendor has performed in accordance with the provisions of this agreement, Gwinnett County shall pay to the vendor, within thirty (30) days of receipt of any department approved payment request and based upon work completed or service provided pursuant to the contract, the sum so requested, less the retainage stated in this agreement, if any. If Gwinnett County fails to pay the vendor within sixty (60) days of receipt of a pay request based upon work completed or service provided pursuant to the contract, the County shall pay the vendor interest at the rate of ½% per month or pro rata fraction thereof, beginning the sixty-first (61<sup>st</sup>) day following receipt of pay requests. The vendor's acceptance of progress payments or final payment shall release all claims for interest on said payment.

The parties agree that this Contract shall be governed and construed in accordance with the laws of the State of Georgia.

**XVI. NON-COLLUSION**

Vendor declares that the submittal is not made in connection with any other vendor's submittal for the same commodity or commodities, and that the submittal is bona fide and is in all respects fair and without collusion or fraud. An affidavit of non-collusion shall be executed by each vendor. Collusion and fraud in submittal preparation shall be reported to the State of Georgia Attorney General and the United States Justice Department.

**XVII. DEFAULT**

The contract may be canceled or annulled by the Purchasing Director in whole or in part by written notice of default to the vendor upon non-performance or violation of contract terms. An award may be made to the next low responsive and responsible vendor, or the next highest scoring responsive and responsible proposer, or articles specified may be purchased on the open market similar to those so terminated. In either event, the defaulting vendor (or their surety) shall be liable to the County for costs to the County in excess of the defaulted contract prices; provided, however, that the vendor shall continue the performance of this contract to the extent not terminated under the provisions of this clause. Failure of the vendor to deliver materials or services within the time stipulated on their offer, unless extended in writing by the Purchasing Director, shall constitute contract default.

**XVIII. TERMINATION FOR CAUSE**

The County may terminate this agreement for cause upon ten days prior written notice to the vendor of the vendor's default in the performance of any term of this agreement. Such termination shall be without prejudice to any of the County's rights or remedies by law.

**XIX. TERMINATION FOR CONVENIENCE**

The County may terminate this agreement for its convenience at any time upon 30 days written

notice to the vendor. In the event of the County's termination of this agreement for convenience, the vendor will be paid for those services actually performed. Partially completed performance of the agreement will be compensated based upon a signed statement of completion to be submitted by the vendor, which shall itemize each element of performance.

**XX. SUBSTITUTIONS**

Vendors offering substitutions or who are deviating from the attached specifications shall list such deviations on a separate sheet to be submitted with their offer. The absence of such a substitution list shall indicate that the vendor has taken no exception to the specifications contained herein.

**XXI. INELIGIBLE VENDORS**

The County may choose not to accept the offer by an individual, firm, or business who is in default on the payment of taxes, licenses, or other monies owed to the County. Additionally, vendors or persons placed on an Ineligible Source List for reasons listed in Part 6, Section II of the Gwinnett County Purchasing Ordinance shall not be eligible to provide any commodities or services to the County during the period such person remains on the Ineligible Source List.

**XXII. PENDING LITIGATION**

An individual, firm, or business that has litigation pending against the County, or anyone representing a firm or business in litigation against the County, not arising out of the procurement process, will be disqualified.

**XXIII. OCCUPATION TAX CERTIFICATE**

Each successful vendor must have a valid Gwinnett County occupation tax certificate if the vendor maintains an office within the unincorporated area of Gwinnett County. Incorporated, out of County, and out of State vendors are required to have any and all certificates necessary to do business in any town, County or municipality in the State of Georgia, or as otherwise required by County ordinance or resolution. Vendors may be required to provide evidence of valid certificates. Out of State vendors are required to have a certificate in the Georgia jurisdiction where they receive the most revenue.

**XXIV. PURCHASING POLICY AND REVIEW COMMITTEE**

The Purchasing Policy & Review Committee has been established to review purchasing procedures and make recommendations for changes; resolve problems regarding the purchasing process; make recommendations for standardization of commodities, schedule buying, qualified products list, annual contracts, supplier performance (Ineligible Source List), and other problems or requirements related to purchasing. The Purchasing Policy & Review Committee has authority to place vendors on the Ineligible Source List for reasons listed in Part 6, Section II of the Gwinnett County Purchasing Ordinance, for a period not to exceed three (3) years.

**XXV. AMERICANS WITH DISABILITIES ACT**

All vendors for Gwinnett County are required to comply with all applicable sections of the Americans with Disabilities Act (ADA) as an equal opportunity employer. In compliance with the Americans with Disabilities Act (ADA), Gwinnett County provides reasonable accommodations

to permit a qualified applicant with a disability to enjoy the privileges of employment equal to those employees without disabilities. Disabled individuals must satisfy job requirements for education background, employment experience, and must be able to perform those tasks that are essential to the job with or without reasonable accommodations. Any requests for the reasonable accommodations required by individuals to fully participate in any open meeting, program or activity of Gwinnett County should be directed to the ADA Coordinator, 75 Langley Drive, Lawrenceville, Georgia 30046, 770-822-8165.

**XXVI. ALTERATIONS OF SOLICITATION AND ASSOCIATED DOCUMENTS**

Alterations of County documents are strictly prohibited and will result in automatic disqualification of the vendor's solicitation response. If there are "exceptions" or comments to any of the solicitation requirements or other language, then the firm may make notes to those areas, but may not materially alter any document language.

**XXVII. TAX LIABILITY**

Local and state governmental entities must notify vendors of their use tax liability on public works projects. Under Georgia law, private vendors are responsible for paying a use tax equal to the sales tax rate on material and equipment purchased under a governmental exemption that is incorporated into a government construction project: excluding material and equipment provided for the installation, repair, or expansion of a public water, gas, or sewer system when the property is installed for general distribution purposes. To the extent the tangible personal property maintains its character (for example, the installation of a kitchen stove), it remains tax-exempt. However, if the installation incorporates the tangible personal property into realty (for example, the installation of sheetrock), it becomes taxable to the private vendor. See O.C.G.A. §48-8-3(2) and O.C.G.A. §48-8-63.

**XXVIII. STATE AND FEDERAL LAW REGARDING WORKER VERIFICATION**

Effective July 1, 2013 State Law requires that all who enter into a contract for the physical performance of services for all labor or service contract(s) that exceed \$2,499.99 (except for services performed by an individual who is licensed pursuant to Title 26, Title 43, or the State Bar of Georgia) and that all who enter into a contract for public works as defined by O.C.G.A. §36-91-2(12) for the County, must satisfy the Illegal Immigration Reform Enhancements for 2013 in conjunction with the Federal Immigration Reform and Control Act (IRCA) of 1986, in all manner, and such are conditions of the contract.

The Purchasing Division Director with the assistance of the Internal Audit Division shall be authorized to conduct random audits of a vendor's or subcontractors' compliance with the Illegal Immigration Reform Enhancements for 2013 and the rules and regulations of the Georgia Department of Labor. The vendor and subcontractors shall retain all documents and records of its compliance for a period of five (5) years following completion of the contract or shall abide by the current time requirements at the time of the contract. This requirement shall apply to all contracts for all public works, labor or service contracts that exceed \$2,499.99 except for services performed by an individual who is licensed pursuant to Title 26, Title 43, or the State Bar of Georgia.

Whenever it appears that a vendor's or subcontractor's records are not sufficient to verify the work eligibility of any individual in the employment of such vendor or subcontractor, the Purchasing Director shall report same to the Department of Homeland Security and may result in termination of the contract if it is determined at any time during the work that the vendor or

subcontractor is no longer in compliance with worker verification.

By submitting an offer to the County, vendor agrees that, in the event the vendor employs or contracts with any subcontractor(s) in connection with the covered contract, the vendor will secure from the subcontractor(s) such subcontractor(s)' indication of the employee-number category applicable to the subcontractor, as well as attestation(s) from such subcontractor(s) that they follow the Illegal Immigration Reform Enhancements for 2013 in conjunction with all federal requirements. Original signed, notarized Subcontractor Affidavits and Agreements must be maintained by the vendor awarded the contract.

A vendor's or subcontractor's failure to participate in the federal work authorization program as defined above shall be subject to termination of the contract. A vendor's failure to follow Gwinnett County's instruction to terminate a subcontractor that is not participating in the federal work authorization program may be subject to termination of the contract.

**XXIX. SOLID WASTE ORDINANCE**

No individual, partnership, corporation, or other entity shall engage in solid waste handling except in such a manner as to conform to and comply with the current Gwinnett County Solid Waste Ordinance and all other applicable local, state and federal legislation, rules, regulation, and orders.

**XXX. GENERAL CONTRACTORS LICENSE**

Effective July 1, 2008: **All General Contractors must have a current valid license from the State Licensing Board for Residential and General Contractors, unless specifically exempted from holding such license pursuant to Georgia law (O.C.G.A. §43-41-17).**

**XXXI. PRODUCTS MANUFACTURED IN GEORGIA**

When contracting for or purchasing supplies, materials, equipment, or agricultural products that exceeds \$100,000.00, excluding beverages for immediate consumption, Gwinnett County shall give preference as far as may be reasonable and practicable to such supplies, materials, equipment, and agricultural products as may be manufactured or produced in this state. Such preference shall not sacrifice quality. Gwinnett County Board of Commissioners shall consider, among other factors, information submitted by the vendor which may include the vendor's estimate of the multiplier effect on gross state domestic product and the effect on public revenues of the state and the effect on public revenues of political subdivisions resulting from acceptance of an offer to sell Georgia manufactured or produced goods as opposed to out-of-state manufactured or produced goods. Any such estimates shall be in writing. **(O.C.G.A. §36-84-1).**

**XXXII. INDEMNIFICATION**

To the fullest extent permitted by law, the vendor shall, at his sole cost and expense, indemnify, defend, satisfy all judgments, and hold harmless the County, its commissioners, officers, agents, and employees from and against all claims, damages, actions, judgments, costs, penalties, liabilities, losses and expenses, including, but not limited to, attorney's fees arising out of or resulting from the performance of the work, provided that any such claim, damage, action, judgment, cost, penalty, liability, loss or expense (1) is attributable to bodily injury, sickness, disease, or death, or to injury to or destruction of tangible property (other than the work itself) including the loss of use resulting therefrom, and (2) is caused in whole or in part by the negligent acts, errors by any act or omission of the vendor, any subcontractor, anyone directly or indirectly employed by any of them or anyone for whose acts any of them may be liable, regardless whether such claim is caused in part by a party indemnified hereunder. Such

obligation shall not be construed to negate, abridge, or otherwise reduce any of the rights or obligations of indemnity which would otherwise exist as to any party or person described in this agreement. In any and all claims against the County, its commissioners, officers, agents, and employees by any employee of the vendor, any subcontractor, anyone directly or indirectly employed by any of them, or anyone for whose acts any of them may be liable, the indemnification obligation contained herein shall not be limited in any way by any limitation on the amount or type of damages, compensation, or benefits payable by or for the vendor or any subcontractor under Worker's Compensation Acts, disability benefit acts, or other employee benefit acts.

Vendor shall also indemnify, hold harmless, insure, and defend the County for damages, losses, or expenses to the extent caused by or resulting from the negligence, recklessness, or intentionally wrongful conduct of the vendor or other persons employed or utilized by the vendor in the performance of a contract that utilizes survey services.

### **XXXIII. CODE OF ETHICS**

Vendors shall disclose under oath the name of all elected officials whom it employs or who have a direct or indirect pecuniary interest in the business entity, its affiliates, or its subcontractors. (This shall not apply to informal purchases as defined by the Purchasing Ordinance.) The vendor shall execute a Code of Ethics affidavit. Failure to submit the affidavit during the procurement process shall render the offer non-responsive.

Any business entity holding a contract with Gwinnett County that after execution of the contract or issuance of the purchase order employs, subcontracts with, or transfers a direct or indirect pecuniary interest in the business entity to an elected official shall within five (5) days disclose such fact in writing under oath to the Clerk of the Board of Commissioners. Failure to comply, or vendors submitting false information or omitting material information shall be referred to the Purchasing Policy & Review Committee for action pursuant to the Purchasing Ordinance or to the District Attorney for possible criminal prosecution. Note: See Gwinnett County Code of Ethics Ordinance E02011, Sec. 54-33. The ordinance is available to view in its entirety at [www.gwinnettcounty.com](http://www.gwinnettcounty.com).

### **XXXIV. ELECTRONIC PAYMENT**

Vendors accepting procurements should select one of Gwinnett County's electronic payment options.

- A. A vendor may select ePayables payment process which allows acceptance of Gwinnett County's virtual credit card as payment for outstanding invoices. The authorized vendor representative must send an email to: [vendorelectronicpayment@gwinnettcounty.com](mailto:vendorelectronicpayment@gwinnettcounty.com) and indicate the desire to enroll in Gwinnett County's virtual credit card payment process.
- B. A vendor may select Direct Deposit payment process and the payment will be deposited directly into an account at their designated financial institution. To securely enroll in Direct Deposit, either access your online [Vendor Login and Registration](#) on the County's web site and update the requested information on the Direct Deposit tab or mail a [Direct Deposit Authorization Agreement](#) form.

The County will send a Payment Advice notification via email for both payment types. For more information about Electronic Payments, please visit the Gwinnett County Treasury Division page or click here -> [Gwinnett County Electronic Payments](#).

**DIRECTIONS TO GJAC BUILDING FROM I-85**

Take I-85 to Georgia Highway 316 (Lawrenceville/Athens exit). Exit Highway 120 (Lawrenceville/Duluth exit) and turn right. At seventh traffic light, turn right onto Langley Drive. Cross Highway 29 through the traffic light and proceed through the roundabout. Visitors can either proceed to the front parking area on the left or to the parking deck behind the building. Click [here](#) for additional information about parking. The Purchasing Division is located on the second floor, West Wing.

FAILURE TO RETURN THIS PAGE MAY RESULT IN REMOVAL OF YOUR COMPANY FROM COMMODITY LISTING.

### BL139-24, Resurfacing of Major County Roads on a Term Contract

Buyer Initials: **MM**

IF YOU DESIRE TO SUBMIT A "NO BID" IN RESPONSE TO THIS PACKAGE, PLEASE INDICATE BY CHECKING ONE OR MORE OF THE REASONS LISTED BELOW AND EXPLAIN.

- Do not offer this product or service; remove us from your bidder's list for this item only.
- Specifications too "tight"; geared toward one brand or manufacturer only.
- Specifications are unclear.
- Unable to meet specifications
- Unable to meet bond requirements
- Unable to meet insurance requirements
- Our schedule would not permit us to perform.
- Insufficient time to respond.
- Other

---



---



---



---



---



---

COMPANY NAME \_\_\_\_\_

AUTHORIZED REPRESENTATIVE \_\_\_\_\_ SIGNATURE

February 01, 2017  
Revised October 22, 2018  
Revised December 7, 2020

## DEPARTMENT OF TRANSPORTATION GWINNETT COUNTY

### SPECIAL PROVISION

#### Section 150—Traffic Control

---

##### 150.1 General Description

This section, as supplemented by the Plans, Specifications, and Manual on Uniform Traffic Control Devices (MUTCD) shall be considered the Temporary Traffic Control (TTC) Plan in accordance with Work Zone Safety and Mobility Policy. Activities shall consist of furnishing, installing, maintaining, and removing necessary traffic signs, pedestrian signs, barricades, lights, signals, cones, pavement markings and other traffic control devices and shall include flagging and other means for guidance and protection of vehicular and pedestrian traffic through the Work Zone. This Work shall include both maintaining existing devices and installing additional devices as necessary in construction work zones.

The contractor shall be responsible for the maintenance of traffic signals and Advanced Traffic Management system (ATMs) devices from the time that the system is modified until final acceptance. The maintenance of traffic signals and ATMs devices that are not a part of the work and that are not in conflict with any portion of the work shall not be the responsibility of the contractor. However, the contractor is still responsible for damages to all devices that he or his subcontractors cause, in accordance with Section 107 and other specifications.

When any provisions of this Specification or the Plans do not meet the minimum requirements of the MUTCD, the MUTCD shall control. The 2009 Edition of the MUTCD including revisions shall be in effect for the duration of the project.

All traffic control devices used during the construction of the project shall meet the standards utilized in the MUTCD, and shall comply with the requirements of these Specifications, Georgia Construction Standards and Details, Project Plans, Design Manuals, and Special Provisions.

The needs and control of all road users (motorists, bicyclists and pedestrians within the highway right-of-way and easements, including persons with disabilities in accordance with the Americans with Disabilities Act of 1990 (ADA), Title II, Paragraph 35.130) through a Temporary Traffic Control (TTC) zone shall be an essential part of highway construction, utility work, maintenance operations and management of traffic incidents.

Utilities included in the contract are bounded by Special Provision 150 and shall follow its requirements. For utilities not included in the contract but working within the project limits, they shall, at a minimum follow the MUTCD. Moreover, in accordance with Utility Accommodation Policy and Standards Manual dated 2016, the Engineer reserves the right to require additional certified flaggers, signs, warning lights, channelization devices, and other safety devices as may be necessary to properly protect, warn, and safeguard the traveling public. In addition, the Department reserves the right to place time restrictions or moratoriums on all utility work covered under a permit when, in the opinion of the Department, the continuance of the Work would seriously hinder traffic flow, be needlessly disruptive, or would unnecessarily inconvenience the traveling public. In case of emergencies, Utilities shall be provided access in accordance with Utility Accommodation Policy and Standard Manual.

### **150.1.01 Definitions**

For Special Provision 150, the definitions for “shall”, “should”, and “may” will be in accordance with MUTCD (1A.13).

Shall (Standard) - a statement of required, mandatory, or specifically prohibitive practice regarding a traffic control device.

Should (Guidance) - a statement of recommended, but not mandatory, practice in typical situations, with deviations allowed if engineering judgment or engineering study indicates the deviation to be appropriate.

May (Option) - a statement of practice that is a permissive condition and carries no requirement or recommendation.

### **150.1.02 Content**

#### **150.1 General Description**

150.1.01 Definitions

150.1.02 Content

150.1.03 Related References

A. Standard Specification B. Reference Documents

150.1.04 Submittals/Preconstruction

A. Worksite Traffic Control Supervisor B. Sequence of Operations

C. Pedestrian Considerations

1. Pedestrian Signage  
2. Temporary Pedestrian Facilities

#### **150.2 Materials and Traffic Control Devices**

150.2.01 Traffic Control Devices

A. NCHRP 350 and MASH  
B. Approval  
C. Quality Guidelines for All Temporary Traffic Devices

150.2.02 Reflectorization Requirements

A. Signs  
B. Channelization Devices

150.2.03 Arrow Panels150.2.04 Channelization DevicesA. General B.  
Drums

1. Design
2. Application
3. Longitudinal Channelization
4. Removal

C. Vertical Panels

1. Design
2. Application

D. Cones

1. Design
2. Applications

E. Barricades

1. Design
2. Application

F. Warning Lights

1. Design
2. Application

150.2.05 Flashing Beacon150.2.06 Guardrail150.2.07 Interim Signs

- A. Posts
- B. Sign Blanks and Panels

150.2.08 Pavement Markings

- |  |           |
|--|-----------|
| <u>A. All Traffic Striping for Forty-Five (45) Days or Less (&lt;=45 Days)</u> | <u>B.</u> |
| <u>All Temporary Striping Beyond Forty-Five (45) days (&gt;45 Days)</u>        | <u>C.</u> |
| <u>All Temporary Traffic Striping on Final Surface</u>                         |           |

150.2.09 Portable Changeable Message Signs150.2.10 Portable Impact Attenuators

150.2.11 Portable Temporary Traffic Control Signals

150.2.12 Raised Pavement Markers

150.2.13 Rumble Strips

150.2.14 Temporary Barriers

A. Design

B. Application

150.2.15 Temporary Guardrail Anchorage- Type 12

150.2.16 Temporary Traffic Signal

### **150.3 Construction Requirements**

150.3.01 General

A. Implementation Requirements

B. Maintenance of Traffic Control Devices C. Traffic Interruption Restrictions

D. Work Zone Restrictions

1. Interstate

2. Non-Interstate Divided Highways

3. Non-Divided Highways

E. Work Zone Geometric Restrictions F. Clear Zone

G. Milled Surface Restrictions H. Construction Vehicle

I. Environmental Impacts

J. Existing Street Lights

K. Nighttime Work Lighting

L. Removal/Reinstallation of Miscellaneous Items

150.3.02 Personnel – Worker Safety Apparel

150.3.03 Signage – General

A. Signing Requirements of the Temporary Traffic Control (TTC) Plan B. Conflicting or Non-Applicable Signs

C. Removal of Existing Signs and Supports

D. Interim Guide, Warning and Regulatory Signs E. Existing Special Guide Signs

1. Special Guide Signs

2. Interim Special Guide Signs

3. Interim Overhead Guide Sign Structures

4. Permanent Special Guide Signs

F. Stop Sign Regulated Intersections

G. Low Shoulder Signage

1. Low Shoulder for Construction/Reconstruction/Resurfacing Projects
2. Shoulder Drop-Off for Construction/Reconstruction/Resurfacing Project

H. Bump SignageI. Sign Visibility150.3.04 Advance Warning SignsA. Project Signs - All Type of Highways

1. State Routes
2. Interstate, Limited Access and Multilane Divided Highways
3. Ramp Work on Limited Access Highways

B. Highway Work Zone

1. No Reduction in the Existing Posted Speed Limit in Highway Work Zone
2. Reducing the Speed Limit in a Highway Work Zone

3. Variable Speed Limit ZonesC. Installation/Removal of Work Area Signage150.3.05 Shoulder/Lane ClosureA. Approval/Restrictions

1. Closure Length
2. Duration

B. Shoulder Closure C.  
Lane Closure

1. Advance Warning Signs
2. Transition Area – Taper
3. Activity Area

4. Termination AreaD. Removal of Lane Closures E. Exit and Entrance  
Ramps150.3.06 Traffic Pacing MethodA. Pacing Of TrafficB. Methods of Signing For Traffic Pacing150.3.07 Flagging OperationA. FlaggersB. Flagger CertificationC. Flagger Appearance and Equipment D.  
Flagger Warning SignsE. Pilot Vehicle RequirementsF. Automated Flagger Assistance DevicesG. Portable Temporary Traffic Control Signals

150.3.08 Traffic Signals

- A. Responsibility/Cost
- B. Law Enforcement Officer Requirement
- C. Variable Message Board Requirement

150.3.09 Mobile Operations150.3.10 Pavement MarkingsA. General

- 1. Resurfacing Projects
- 2. Widening and Reconstruction Projects
- 3. New Location Construction Projects

B. Installation and Removal of Pavement Markings

- 1. Installation
- 2. Removal
- 3. Intermediate Surface
- 4. Final Surface
- 5. Pay Factor Reduction for Asphaltic Concrete Final Surfaces
- 6. Preparation and Planning for Traffic Shifts

C. Raised Pavement Markers

- 1. Supplementing Lane Lines
- 2. Supplementing Ramp Gore Lines
- 3. Other Lines

D. Exceptions for Interim Markings

- 1. Two-Lane, Two-Way Roadway
- 2. Multi-Lane Highway – with No Paved Shoulder(s) or Paved Shoulder(s) Four Feet or Less ( $\leq 4'$ )
- 3. Limited Access Roadways and Roadways with Paved Shoulder Greater than Four Feet ( $>4'$ )
- 4. Ramps for Multi-lane Divided Highways
- 5. Miscellaneous Pavement Markings

150.3.11 Differences in Elevation between Travel Lanes and ShouldersA. Differences in Elevations

- 1. Difference of Two Inches ( $\leq 2''$ ) or Less Between Adjacent Travel Lanes
- 2. Difference of Two Inches ( $\leq 2''$ ) or Less Between Adjacent Travel Lane and Paved Shoulder Should
- 3. Difference of Greater Than Two Inches ( $>2''$ ) is Permitted for Continuous Operations
- 4. Difference of Greater Than Two Inches ( $>2''$ ) Between Travel Lanes and/or Shoulders

for Non-Continuous Operations

- B. Healed Section
- C. Emergency Situations
- D. Plating
- E. Asphaltic Concrete Resurfacing Projects

1. Shoulder Construction Included as a Part of the Contract
2. Shoulder Construction Not Included as a Part of the Contract

150.3.12 Work Zone Law Enforcement

**150.4 Measurement**

150.4.01 Traffic Control Items

- A. Traffic Control
- B. Changeable Message Sign, Portable C. Flashing Beacon Assembly
- D. Pavement Markings
- E. Portable Impact Attenuators
- F. Signs

1. Interim Ground Mounted or Interim Overhead Special Guide Signs
2. Remove And Reset Existing Special Guide Signs, Ground Mount or Overhead
3. Modify Special Guide Signs, Ground Mount or Overhead

G. Temporary Audible Information Device

H. Temporary Barrier

- I. Temporary Curb Cut Wheelchair Ramps J. Temporary Guardrail Anchorage, Type 12  
K. Temporary Walkways with Detectable Edging L. Traffic Signal Installation - Temporary  
M. Work Zone Law Enforcement

**150.5 Reserved**

**150.6 Special Conditions**

**150.7 Payment**

150.7.01 Enforcement and Adjustments

### 150.1.03 Related References

#### A. Standard Specifications

Section 104 - Scope of Work

Section 105 - Control of Work - Legal Regulations and Responsibility to the Public Section

107 - Legal Regulations and Responsibility to the Public

Section 108 - Prosecution and Progress Section

209 - Subgrade Construction

Section 400 - Hot Mix Asphaltic Concrete Construction

Section 441 - Miscellaneous Concrete

Section 429 - Rumble Strips Section

620 - Temporary Barrier

Section 632 - Portable Changeable Message Signs Section

641 - Guardrail

Section 647 - Traffic Signal Installation

Section 648 - Traffic Impact Attenuator

Section 652 - Painting Traffic Stripe Section

653 - Thermoplastic Traffic Stripe Section 654

- Raised Pavement Markers

Section 656 - Removal of Pavement Markings Section

657 - Preformed Plastic Pavement Markings

Section 658 - Standard and Wet Weather Polyurea Traffic Stripe

Section 659 - Hot Applied Preformed Plastic Pavement Markings

Section 911 - Sign Posts

Section 912 - Sign Blanks and Panels Section

913 - Reflectorizing Materials

**B. Referenced Documents**

ASTM D4956-13 (Retro-reflectivity)

American Traffic Safety Services Association (ATSSA)

Construction Detail A-3 Curb Cut (Wheelchair) Ramps Concrete Sidewalk Details

Construction Detail A-4 Detectable Warning Surface Truncated Dome Size, Spacing and Alignment Requirements

Construction Detail T-3A (Type 7, 8, and 9 Square Tube Post Installation Detail)

GDOT Signing and Marking Design Guidelines

Georgia Standard 4000W “Lengths of Advancement, Clear Zone Distances, Fill Height Embankment”

Georgia Standard 4960 “Temporary Barrier (End Treatment Options)”

Georgia Standard 9102 “Traffic Control Detail for Lane Closure on Two-Lane Highway”

Georgia Standard 9106 “Traffic Control Detail for Lane Closure on Multi-Lane Divided Highway”

Georgia Standard 9107 “Traffic Control Detail for Lane Closure on Multi-Lane Undivided Highway”

Georgia Standard 9121 “Tapers, Signs, and Markings for Passing Lanes”

Manual for Assessing Safety Hardware (MASH) Manual

on Uniform Traffic Control Devices (MUTCD)

National Cooperative Highway Research Program (NCHRP) 350

National Safety Council

Quality Product List #29 (QPL-29) Reflective Sheeting

Quality Product List #34 (QPL-34) Work Zone Traffic Control Devices (Drums, Type III Barricades, Vertical Panels, and Portable Sign Systems)

Quality Product List #35 (QPL-35) Drive Type Galvanized Steel Sign Posts

Quality Product List #46 (QPL-46) Traffic Pavement Markings

Quality Product List #64 (QPL-64) Attenuator Units (Compression Crash Cushion) and Guardrail End Treatments

Quality Product List #76 (QPL-76) Raised Pavement Markers and Channel Markers

Quality Product List #79 (QPL -79) Portable Arrow Boards

Quality Product List #82 (QPL -82) “Portable Changeable Message Signs”

Utility Accommodation Policy and Standards Manual

Work Zone Safety and Mobility Policy

#### 150.1.04 Submittals/Preconstruction

##### A. Worksite Traffic Control Supervisor

The Contractor shall designate a qualified individual as the Worksite Traffic Control Supervisor (WTCS). The WTCS shall be responsible for selecting, installing and maintaining all traffic control devices in accordance with the Plans, Specifications, Special Provisions and the MUTCD. The WTCS shall be currently certified by the American Traffic Safety Services Association (ATSSA) Work Site Traffic Supervisor Certification program or the National Safety Council Certification program. On-line classes will not be accepted.

The WTCS shall be available on a twenty-four (24) hour basis to perform his duties. If the work requires traffic control activities to be performed during the daylight and nighttime hours, it may be necessary for the Contractor to designate an alternate WTCS. An alternate WTCS must meet the same requirements and qualifications as the primary WTCS and be accepted by the Engineer prior to beginning any traffic control duties. The Worksite Traffic Control Supervisor's traffic control responsibilities shall have priority over all other assigned duties.

As the representative of the Contractor, the WTCS shall have full authority to act on behalf of the Contractor in administering the TTC Plan. The WTCS shall have appropriate training in safe traffic control practices in accordance with Part 6 of the MUTCD. In addition to the WTCS, all other individuals making decisions regarding traffic control shall meet the training requirements of the Part 6 of the MUTCD.

The Worksite Traffic Control Supervisor (WTCS) shall have a copy of Part 6 of the MUTCD and the Contract on the job site. Copies of the current MUTCD may be obtained from the FHWA web page at <http://mutcd.fhwa.dot.gov>.

The WTCS shall supervise the initial installation of traffic control devices. The Engineer, prior to the beginning of construction, will review the initial installation. Modifications to traffic control devices as required by sequence of operations or staged construction shall be reviewed by the WTCS.

Any work performed on the interstate or limited access highway right-of-way that requires traffic control shall be supervised by a submitted/approved certified Worksite Traffic Control Supervisor. No work requiring traffic control shall be performed unless the certified WTCS is on the worksite. Failure to maintain a Certified Worksite Traffic Control Supervisor on the work will be considered as non-performance under Subsection 150.7.01.

The WTCS or alternate WTCS shall be available on a full-time basis to maintain traffic control devices with access to all personnel, materials, and equipment necessary to respond effectively to an emergency situation within forty-five (45) minutes of notification of the emergency.

The WTCS shall regularly perform inspections to ensure that traffic control is maintained. Unless modified by the special conditions or by the Engineer, routine deficiencies shall be corrected within a twenty-four (24) hour period. Failure to comply with these provisions shall be grounds for dismissal from the duties of WTCS and/or removal of the WTCS from the project. Failure of the WTCS to execute their duties shall be considered as non-performance under Subsection 150.7.01.

The designated Contractor's representative charged with the responsibility for traffic control on this project will review the project at least twice a week after dark, but prior to midnight to ensure that all traffic control devices have been installed and maintained properly and is adequate to provide the necessary protection to the traffic in addition to the normal daily maintenance. The Traffic Control Inspection Report, (TC-1) for the after dark reviews will be submitted outlining the findings and recommended corrections including the specified time frame for accomplishing this work. The written reports are to be submitted weekly every Monday (for the previous week) to:

Atlas Technical Consultants, LLC, 2450 Commerce Avenue, Suite 100  
Duluth, Georgia 30096 Attention: Mr. Hank Collins

**TRAFFIC CONTROL INSPECTION REPORT (TC-1)**

Project No.: \_\_\_\_\_ County: \_\_\_\_\_

Contractor: \_\_\_\_\_ Date: \_\_\_\_\_ Daytime: \_\_\_\_\_

Nighttime: \_\_\_\_\_

PURPOSE: To provide adequate warning, delineation, and channelization to assist in guiding road users in advance of and through the work zone by utilizing proper pavement markings, signs, and other MUTCD compliant devices.

RESPONSIBILITY: The Worksite Traffic Control Supervisor (WTCS) has the duty of ensuring that all traffic control devices are installed and maintained according to the requirements of the Traffic Control Plan.

DEFICIENCIES: Items noted below required corrective measures be performed with the next hours/days.

LOCATION	DESCRIPTION	ACTION REQUIRED
_____	_____	_____
_____	_____	_____
_____	_____	_____

(use additional sheets if needed) Signature: \_\_\_\_\_ WTCS or DOT performing inspection \_\_\_\_\_

DOT inspection presented to WTCS Date: \_\_\_\_\_ Time: \_\_\_\_\_

**TO BE COMPLETED BY THE WTCS**

The attached deficiencies were corrected by Date: \_\_\_\_\_ Time: \_\_\_\_\_

Signature \_\_\_\_\_ Return TC-1 to DOT inspector.

The WTCS certifies that all traffic control devices in use on the project are MASH/NCHRP 350 crashworthy compliant.

Traffic Control Checklist

Satisfactory Unsatisfactory Non-applicable

Signs

 S

 U

 N

- Are the signs correctly installed?
- Signs are in place according to TTC plans. Signs are plumb and level. Signs are at the proper height.
- Are the signs visible and readable to the public both daytime and nighttime?
- Is retroreflectivity good?
- Are signs not in use including PCMS properly stored?

TTC Devices

 S

 U

 N

- Are they MASH/NHCRP 350 approved? Do they meet MUTCD and Special Provision 150 requirements?
- Are they installed according to manufacture recommendation?
- Are they in acceptable/marginal condition? Are they stable? Is the retroreflectivity good?

Clear Zone

 S

 U

 N

- Are all material and equipment stored beyond the clear zone?
- If stored in clear zone, are they protected by positive barrier?
- Are drop-off marked and healed according to Special Provision 150?

Positive Barriers

 S

 U

 N

- Are the barriers in acceptable/marginal condition and FHWA approved?
- Are the barrier reflectors proper and in good condition?
- Do the barriers extend to the proper advancement length? Are the tapers according to GA Standards?

Attenuators and Guardrails

 S

 U

 N

- Are the proper attenuators assemblies in use?
- Gating Is the recovery area free of debris and provide the necessary recovery area?
- Is the assembly in accordance with manufacture recommendation?
- Are the guardrails properly anchor and/or attached to the barrier?
- Are shoes and transition sections in accordance with Standards?

Pavement Markings

 S

 U

 N

- Are the pavement making visible and legible?
- Can they be seen during the daytime and nighttime?
- Are there no conflicting pavement markings?
- Are the pavement markings including RPM installed and maintained according to section 150?

The Engineer will periodically review the work for compliance with the requirements of the TTC plan.

On projects where traffic control duties will not require full time WCTS supervision, the Engineer may allow the Contractor's Project superintendent, foreman, subcontractor, or other designated personnel to serve as the WTCS as long as satisfactory results are obtained. Nevertheless, the individual shall meet the requirements and perform the duties of a WTCS.

## **B. Sequence of Operations**

Any Sequence of Operations provided in this Contract in conjunction with any staging details which may be shown in the plans, is a suggested sequence for performing the Work. It is intended as a general staging plan for the orderly execution of the work while minimizing the impact on pedestrian facilities, mainline, cross- streets and side streets. The Contractor shall develop detailed staging and temporary traffic control plans for performing specific areas of the Work including but not limited to all traffic shifts, detours, bridge widenings, paces, or other activities that disrupt traffic or pedestrian flow. The Engineer may require detailed staging and TTC plans for lane closures or disruption to pedestrian facilities. These plans shall be submitted for approval at least two (2) weeks prior to the scheduled date of the activity. Activities that have not been approved at least seven (7) days prior to the scheduled date shall be rescheduled.

Where traffic is permitted through the work area under stage construction, the Contractor may choose to construct, at no additional expense to the Department, temporary on-site bypasses or detours in order to expedite the work. Plans for such temporary bypasses or detours shall be submitted to the Engineer for review and approval thirty (30) calendar days prior to the proposed construction. Such bypasses or detours shall be removed promptly when in the opinion of the Engineer; they are no longer necessary for the satisfactory progress of the Work. Bypasses and detours shall meet the minimum requirements of Subsection 150.3.01.D.

As an option to the Sequence of Operations in the Contract, the Contractor may submit an alternative Sequence of Operations for review and approval. Alternate Sequence of Operations for pedestrian facilities shall be in compliance with the MUTCD and ADA. Pedestrian needs identified in the preconstruction phase shall be included in the proposed alternate plan.

The Department will not pay, or in any way, reimburse the Contractor for claims arising from the Contractor's inability to perform the Work in accordance with the Sequence of Operations provided in the Contract or from an approved Contractor alternate.

The Contractor shall secure the Engineer's approval of the Contractor's proposed plan of operation, sequence of work and methods of providing for the safe passage of vehicular and pedestrian traffic before it is placed in operation. The proposed plan of operation shall supplement the approved traffic control plan. Any major changes to the approved TTC plan, proposed by the Contractor, shall be submitted to the Department for approval.

Some additional traffic control details will be required prior to any major shifts or changes in traffic. The traffic control details shall include, but not be limited to, the following:

1. A detailed drawing showing traffic locations and lanes for each step of the change.
2. The location, size, and message of all signs required by the MUTCD, Plan, Special Provisions, and other signs as required to fit conditions. Any portable changeable message signs used shall be included in the details.
3. The method to be used in, and the limits of, the obliteration of conflicting lines and markings.
4. Type, location, and extent of new lines and markings.

5. Horizontal and vertical alignment and superelevation rates for detours, including cross-section and profile grades along each edge of existing pavement.
6. Drainage details for temporary and permanent alignments.
7. Location, length, and/or spacing of channelization and protective devices (temporary barrier, guardrail, barricades, etc.)
8. Starting time, duration and date of planned change.
9. For each traffic shift, a paving plan, erection plan, or work site plan, as appropriate, detailing workforce, materials, and equipment necessary to accomplish the proposed work. This will be the minimum resource allocation required in order to start the work.

A minimum of three (3) copies of the above details shall be submitted to the Engineer for approval at least fourteen (14) days prior to the anticipated traffic shift. The Contractor shall have traffic control details for a traffic shift which has been approved by the Engineer prior to commencement of the physical shift. All preparatory work relative to the traffic shift, which does not interfere with traffic, shall be accomplished prior to the designated starting time. The Engineer and the Contractor's representative will verify that all conditions have been met prior to the Contractor obtaining materials for the actual traffic shift.

### C. Pedestrian Considerations

All existing pedestrian facilities, including access to transit stops, shall be maintained. Where pedestrian routes are closed, alternate routes shall be provided. Closures of existing, interim and final pedestrian facilities shall have the prior written approval of the Engineer. When existing pedestrian facilities are disrupted, closed or relocated in a TTC zone, the temporary facilities shall be detectable and shall include accessibility features consistent with the features present in the existing pedestrian facility. Pedestrian facilities are considered improvements and provisions made to accommodate or encourage walking. Whenever a sidewalk is to be closed, the Engineer shall notify the maintaining agency two (2) weeks prior to the closure. Prior to closure, detectable barriers (that are detectable by a person with a visual disability traveling with the aid of a long cane), as described by the MUTCD, shall be placed across the full width of the closed sidewalk. Barriers and channelizing devices used along a temporary pedestrian route shall be in compliance with the MUTCD.

Temporary Traffic Control devices used to delineate a Temporary Traffic Control Zone Pedestrian Walkway shall be in compliance with Subsection 150.3.01.A. Appropriate signs as described in the MUTCD shall be maintained to allow safe passage of pedestrian traffic or to advise pedestrians of walkway closures (Refer to MUTCD Figures TA-28 and TA-29 for guidance). Advance closure signing should be placed at intersections rather than midblock locations so that pedestrians are not confronted with midblock work sites that will induce them to attempt skirting the work site or making a midblock crossing. Temporary Traffic Control devices and construction material shall not intrude into the usable width of the pedestrian walkway. Signs and other devices shall be placed such that they do not narrow or restrict any pedestrian passage to less than forty-eight inches ( $\geq 48''$ ).

#### 1. Pedestrian Signage

A pedestrian walkway shall not be severed or relocated for non-construction activities, such as parking for construction vehicles and equipment. Movement by construction vehicles and equipment across designated pedestrian walkways should be minimized. When necessary, construction activities shall be controlled by flaggers. Pedestrian walkways shall be kept free of mud, loose gravel or other debris.

When temporary covered walkways are used, they shall be lighted during nighttime hours. When temporary traffic barrier is used to separate pedestrian and vehicular traffic, the temporary barrier shall meet NCHRP-350 Test Level Three. The barrier ends shall be protected in accordance with Georgia

Standard 4960. Curbing shall not be used as a substitute for temporary traffic barriers when temporary traffic barriers are required. Tape, rope or plastic chain strung between temporary traffic control devices are not considered as detectable and shall not be used as a control for pedestrian movements.

The WTCS shall inspect the activity area daily to ensure that effective pedestrian TTC is being maintained. The inspection of TTC for pedestrian traffic shall be included as part of the TC-1 report.

## 2. Temporary Pedestrian Facilities

Temporary pedestrian facilities shall be detectable and include accessibility features consistent with the features present in the existing pedestrian facility. The geometry, alignment and construction of the facility should meet the applicable requirements of the "Americans with Disabilities Act Accessibility Guidelines for Buildings and Facilities (ADAAG)".

### a. Temporary Walkways with Detectable Edging

A smooth, continuous hard surface (firm, stable and slip resistant) shall be provided throughout the entire length of the temporary pedestrian facility. Compacted soils, sand, crushed stone or asphaltic pavement millings shall not be used as a surface course for walkways.

Temporary walkways shall include detectable edging as defined in the MUTCD. When temporary traffic barrier is included as a pay item in the contract and where locations identified on the plans for positive protection will also allow them to serve as pedestrian detectable edging, payment will be made for the temporary traffic barrier in accordance with Section 620. No payment will be made for temporary walkways with Detectable Edging where existing pavements or existing edging (that meets the requirements of MUTCD) are utilized as temporary walkways. Payment for temporary detectable edging, including approved barriers and channelizing devices, installed on existing pavements shall be included in Traffic Control-Lump Sum.

Regardless of the materials used, temporary walkways shall be constructed with sufficient thickness and durability to withstand the intended use for the duration of the construction project. If concrete or asphalt is used as the surface course for the walkway, it shall be a minimum of one and one-half inches ( $\geq 1\text{-}1/2''$ ) thick. Temporary walkways constructed across unimproved streets and drives shall be a minimum thickness of four inches ( $\geq 4''$ ) for concrete and three inches ( $\geq 3''$ ) for asphalt. Joints formed in concrete sidewalks shall be in accordance with Section 441 Concrete surfaces shall have a broom finish.

If plywood is used as a walkway, it must be a minimum of three quarters of an inch ( $\geq 3/4''$ ) thick, pressure treated and supported with pressure treated longitudinal joists spaced a maximum of sixteen inches ( $\leq 16''$ ) on center. The plywood shall be secured to the joist with galvanized nails or galvanized deck screws. Nails and screws shall be countersunk to prevent snagging or tripping the pedestrians. A slip resistant friction course shall be applied to any plywood surface that is used as a walkway. Any slip resistant material used shall have the prior written approval of the engineer.

The contractor may propose alternate types of Temporary Walkways provided that the contractor can document that the proposed walkway meets the requirements of the "Americans with Disabilities Act Accessibility Guidelines for Buildings and Facilities (ADAAG)". Alternate types of Temporary Walkways shall have the prior written approval of the engineer.

Temporary walkways shall be constructed and maintained so there are no abrupt changes in grade or terrain that could cause a tripping hazard or could be a barrier to wheelchair use. The contractor shall construct and maintain the walkway to ensure that joints in the walkway have a vertical difference in elevation of no more than one quarter ( $\leq 1/4''$ ) of an inch and that the horizontal joints have gaps no greater than one half ( $\leq 1/2''$ ) of an inch. The grade of the temporary walkway should parallel the grade of the existing walkway or roadway and the cross slope should be no greater than two percent ( $\leq 2\%$ ).

A width of sixty inches (60”), if practical, should be provided throughout the entire length of any temporary walkway. The temporary walkway shall be a minimum width of forty eight inches (48”). When it is not possible to maintain a minimum width of sixty inches (60”) throughout the entire length of temporary walkway, a sixty inch (60”) by sixty inch (60”) passing space should be provided at least every two hundred feet (200 ft.), to allow individuals in wheelchairs to pass.

Temporary walkways shall be constructed on firm subgrade. Compact the subgrade according to Section 209. Furnish and install any needed temporary pipes prior to constructing any walkway to ensure positive drainage away from or beneath the temporary walkway. Once the walkway is no longer required, remove any temporary materials and restore the area to the original conditions or as shown in the plans.

b. Temporary Curb Cut Wheelchair Ramps

Temporary curb cut wheelchair ramps shall be constructed in accordance with Section 441 and Construction Detail A-3 Curb Cut (Wheelchair) Ramps Concrete Sidewalk Details. Ramps shall also include a detectable warning surface in accordance with Construction Detail A-4 Detectable Warning Surface Truncated Dome Size, Spacing and Alignment Requirements. Other types of material for the construction of the temporary curb cut wheelchair ramps, including the detectable warning surface, may be used provided the contractor can provide documentation that the material to be used meets the requirements of the “Americans with Disabilities Act Accessibility Guidelines for Buildings and Facilities (ADAAG)”. When a wheelchair ramp is no longer required, remove the temporary materials and restore the area to existing conditions or as shown in the plans. For the items required to restore the area to original conditions or as shown in the plans, measures for payment shall be covered by contract pay items. If pay items are not included in the contract, then payment for these items shall be included in Traffic Control-Lump Sum.

c. Temporary Audible Information Device

Temporary audible information devices, when shown in the plans, shall be installed in compliance with the “Americans with Disabilities Act Accessibility Guidelines for Buildings and Facilities (ADAAG)”. The devices shall be installed in accordance with the manufacturer’s recommendations. Prior to installation, the contractor shall provide the engineer with a set of manufacturer’s drawings detailing the proper installation procedures for each device. When no longer required, the devices shall remain the property of the contractor.

## 150.2 Materials and Traffic Control Devices

### 150.2.01 Traffic Control Devices

#### A. NCHRP 350 and MASH

All devices shall be certified in accordance with the Manual for Assessing Safety Hardware (MASH) Test Level 3 and/or the National Cooperative Highway Research Program (NCHRP) 350 Test Level 3 as applicable unless modified by this Special Provision. In addition, temporary work zone devices, including portable barriers, manufactured after December 31, 2019, must have been successfully tested under 2016 edition of MASH requirements. Such devices manufactured on or before this date, and successfully tested under either NCHRP Report 350 or the 2009 edition of MASH, may continue to be used throughout their normal service lives.

## B. Approval

All traffic control devices with applicable Qualified Products List (QPL) categories shall come from the appropriate QPL list. Products not on the QPL may be used with an approval letter from the Georgia Department of Transportation Office of Materials and Testing. If there are no applicable QPL, the Contractor shall provide proof of MASH/NCHRP 350 certification. The proof may be a letter or written statement from the manufacturer that the product is MASH/NCHRP 350 approved. Decal certifications are not proof of certification and are not required.

## C. Quality Guidelines for All Temporary Traffic Devices

All traffic control devices found to be unacceptable in accordance with the current ATSSA, "Quality Guidelines for Temporary Traffic Devices and Features" regardless of total numbers shall be replaced within twenty-four (24) hours unless stated otherwise in the specifications, in the contract, or as directed by the Engineer.

### 150.2.02 Retroreflectivity Requirements

#### A. Signs

Reflective sheeting should meet the requirements of Section 913 and QPL-29

All construction warning signs (black on fluorescent orange) shall meet the minimum reflectivity and color requirements of ASTM D4956 Type XI regardless of the mounting height. All other signs reflectorization shall be in accordance with the plans, contract, and "GDOT Signing and Marking Design Guidelines".

#### B. Channelization Devices

Reflective sheeting should meet the requirements of Section 913 and QPL-29

All channelization devices (white/ fluorescent orange and white/red) shall meet the minimum retroreflectivity requirements of ASTM D4956 Type VI.

### 150.2.03 Arrow Panels

Arrow panel should meet the requirements for MUTCD (6F.61) and QPL-79.

Portable sequential arrow, sequential chevron, or flashing arrow panels shall be a minimum size of forty-eight inches (48") high by ninety-six inches (96") wide with not less than fifteen (15) lamps used for the arrow. The arrow shall occupy virtually the entire size of the arrow panel and shall have a minimum legibility distance of one (1) mile. The minimum legibility distance is the distance at which the arrow panel can be comprehended by an observer on a sunny day, or clear night. Arrow panels shall be equipped with automatic dimming features for use during hours of darkness. The arrow panels shall also meet the requirements for a Type C panel as shown in the MUTCD (6F.61). The sequential or flashing arrow panels shall not be used for lane closure on two-lane, two-way highways when traffic is restricted to one-lane operations in which case, appropriate signing, flaggers and when required, pilot vehicles will be deemed sufficient.

The arrow panels shall be placed on the shoulder at or near the point where the lane closing transition begins. The panels shall be mounted on a vehicle, trailer, or other suitable support. Vehicle mounted panels shall be provided with remote controls. Minimum mounting height shall be seven feet (7') above the roadway to the bottom of the panel, except on vehicle mounted panels which should be as high as practical.

For emergency situations, arrow display panels that meet the MUTCD requirements for Type A or Type B panels may be used until Type C panels can be located and placed at the site. The use of Type A and Type B panels shall be held to the minimum length of time possible before having the Type C panel(s) in operation. The Engineer shall determine when conditions and circumstances are considered to be emergencies. The Contractor shall notify the Engineer, in writing, when any non-specification arrow display panel(s) is being used in the work.

#### **150.2.04 Channelization Devices**

##### **A. General**

Channelization shall clearly delineate the travel way through the work zone and alert drivers and pedestrians to conditions created by work activities in or near the travel way. Channelization shall be accordance with the plans, specifications, MUTCD, QPL-34, and the following requirements.

##### **B. Drums**

###### 1. Design

Drums shall meet the minimum requirement of the MUTCD (6F.67). Drums shall have six inch (6") wide stripes – white/fluorescent orange.

###### 2. Application

Drums shall be used as the required channelizing device to delineate the full length of a lane closure, shift, or encroachment, except as modified by this Subsection.

###### 3. Longitudinal Channelization

Drums shall be spaced as listed below for various roadside work conditions except as modified by Subsection 150.3.11. Spacing shall be used for situations meeting any of the conditions listed as follows:

###### a. FORTY FOOT (40') SPACING MAXIMUM

- For difference in elevation exceeding two inches ( $> 2''$ ).
- For heeled sections no steeper than 4:1 as shown in Subsection 150.3.11, Detail 150-H.

###### b. EIGHTY FOOT (80') SPACING MAXIMUM

- For difference in elevation of two inches ( $\leq 2''$ ) or less.
- Flush areas where equipment or workers are within ten feet ( $\leq 10'$ ) of the travel lane.

- c. 200 FOOT SPACING MAXIMUM: Where equipment or workers are more than ten feet ( $> 10'$ ) from travel lane. Lateral offset clearance to be four feet ( $4'$ ) from the travel lane.
- For paved areas, eight feet ( $> 8'$ ) or greater in width that are paved flush with a standard width travel lane.
  - For disturbed shoulder areas not completed to typical section that are flush to the travel lane and considered a usable shoulder.

#### 4. Removal of Drums

Drums may be removed after shoulders are completed to typical section and grassed. Guardrail and other safety devices shall be installed and appropriate signs advising of conditions such as soft or low shoulder shall be posted before the drums are removed.

### C. Vertical Panels

#### 1. Design

All vertical panels shall meet the minimum requirements of the MUTCD (6F.66). All vertical panels shall have a minimum of 270 square inches of retroreflective area facing the traffic and be a minimum thirty-six inches ( $\geq 36''$ ) high. For all projects let June 2018 and afterward, the vertical panel shall be in addition a minimum eight inches ( $\geq 8''$ ) wide with a stripe width of six inches ( $6''$ ) – white/fluorescent orange.

#### 2. Application

Vertical panels with retroreflectivity less than type VI can only be used when traffic drums reduce the travel lane to less than ten feet ( $\leq 10'$ ); vertical panels shall be used to restore the travel lane to ten feet ( $\geq 10'$ ) or greater. No other application of vertical panels with retroreflectivity less than type VI will be permitted.

Vertical panels with a minimum type VI retroreflectivity and six inch ( $6''$ ) stripe may be used for longitudinal channelization in the activity zone where work takes place for short-term stationary lane closures and intermediate-term stationary lane closures. They can be used for lane closures lasting three (3) days and with Engineer approval up to seven (7) days. They shall not be used in the transition zone including the tapers and the tangent lengths between tapers.

### D. Cones

#### 1. Design:

All cones shall be a minimum of twenty-eight inches ( $\geq 28''$ ) in height regardless of application and shall meet the requirements of the MUTCD (6F.64).

Retroreflectivity may be deleted from all cones.

## 2. Application

On interstate cones shall be prohibited. On all other routes cones may only be used for longitudinal channelization in the activity zone where work takes place for short-term stationary lane closures. They shall not be used in the transition zone including the tapers and the tangent lengths between tapers. The use of cones for nighttime work will not be permitted. Cones shall not be stored or allowed to be visible on the worksite during nighttime.

Cones may be used for daytime flagging operations including tapers at flagging stations.

## E. Barricades

### 1. Design

Type 3 barricades shall meet the minimum requirements of the MUTCD (6F.68). The Contractor has the option of choosing Type 3 barricades from the QPL-34 or the Contractor may utilize generic barricades that are approved by the Federal Highway Administration (FHWA). When barricades have been specifically crash tested with signs attached, the contractor has the responsibility to attach the signs as per the manufacturer's recommendations to ensure crashworthiness. If the barricades were not tested with the signs, crashworthy compliance may require that rigid signs be mounted separate from the Type 3 barricade.

The use of Type 1 and Type 2 barricades will not be permitted.

### 2. Application

Type 3 barricades shall be placed as required by the plans, the Standards, and as directed by the Engineer.

When a barricade is placed so that it is subject to side impact from a vehicle, a drum shall be placed at the side of the barricade to add target value to the barricade.

## F. Warning Lights

### 1. Design

All warning lights shall meet the requirements of the MUTCD (6F.83).

### 2. Application:

- a. Type A low-intensity flashing lights shall be used as shown in the Plans, the Standards, and as directed by the Engineer.
- b. Type C Steady-Burn lights shall be used as shown in the Plans, the Standards, and as directed by the Engineer.

## 150.2.05 Flashing Beacon

The flashing beacon assembly, when specified, shall be used in conjunction with construction warning signs, regulatory, or guide signs to inform traffic of special road conditions which require additional driver attention. The flashing beacon assembly shall be installed in accordance with the requirements of Section 647.

### 150.2.06 Guardrail

Guardrail shall comply with Section 641 Guardrail and the guardrail standards.

When the removal and installation of guardrail is required, as a part of the work, the following time restrictions shall apply unless modified by the special conditions:

From the time that the existing guardrail or temporary positive barrier protection is removed, the Contractor has fourteen (14) days to install the new guardrail and anchors. During the interim, the location without guardrail shall be protected with drums spaced at a maximum spacing of twenty feet (20'). The guardrail blunt end is to be treated as a fix object and shall be projected. The maximum length of rail that can be removed at any time without being replaced with positive barrier protection is a total of 2000 linear feet of existing rail or the total length of one run of existing rail, whichever is less. Based on existing field conditions, the Engineer may review the work and require that the guardrail be installed earlier than the maximum time allowed.

The contractor shall install new guardrail, such that traffic exposure to fixed objects is minimized. Within the same workday, temporary attenuators, as defined in Subsection 150.2.10, should be installed on the approach to fixed objects that can't be protected with guardrail. Truck mounted attenuators may be used to shield exposed fixed objects for periods not to exceed fourteen (14) days. No separate payment will be made for truck mounted attenuators, attenuators, or other methods unless provided for in the contract.

When the roadway is open to traffic, guardrail panels shall be lapped to comply with the directional flow of traffic. Should the staging of the work require that the lap of the guardrail be changed, this work shall be completed before the roadway is opened to traffic. The work to change the lap of any guardrail shall be included in Traffic Control- Lump Sum.

The laps on anchors shall be in accordance with the manufacture's recommendations and installation instructions. As a result, a trailing anchor may be lapped opposing the flow of traffic.

Failure to comply with the above time and quantity restrictions shall be considered as non-compliance under Subsection 150.7.01.

### 150.2.07 Interim Signs

#### A. Posts

Permanent mounting height to the bottom of sign shall be seven (7) feet – eight (8) feet measured vertically from the bottom of the sign to the elevation of the near edge of the pavement or from the walkway. Posts for all interim signs should be square tubular post meeting the requirements of Section 911, QPL-35, and Construction Detail T-3A (Type 7, 8, and 9 Square Tube Post Installation Detail). Ground mounted sign(s) greater than 48" wide shall be mounted on two posts. For barrier mounted sign, single post mount is allowed.

The post(s) shall not extend beyond the top of the sign(s). The sign(s) shall be substantially plumbed and leveled.

Unprotected interim posts shall be spliced as shown in Detail 150-A, unless full length unspliced posts are used. Unprotected post splices will not be permitted any higher than four inches above the ground line to lessen the possibility of affecting the undercarriage of a vehicle. Installation of posts may require establishment of openings in existing pavements, islands, shoulders etc.

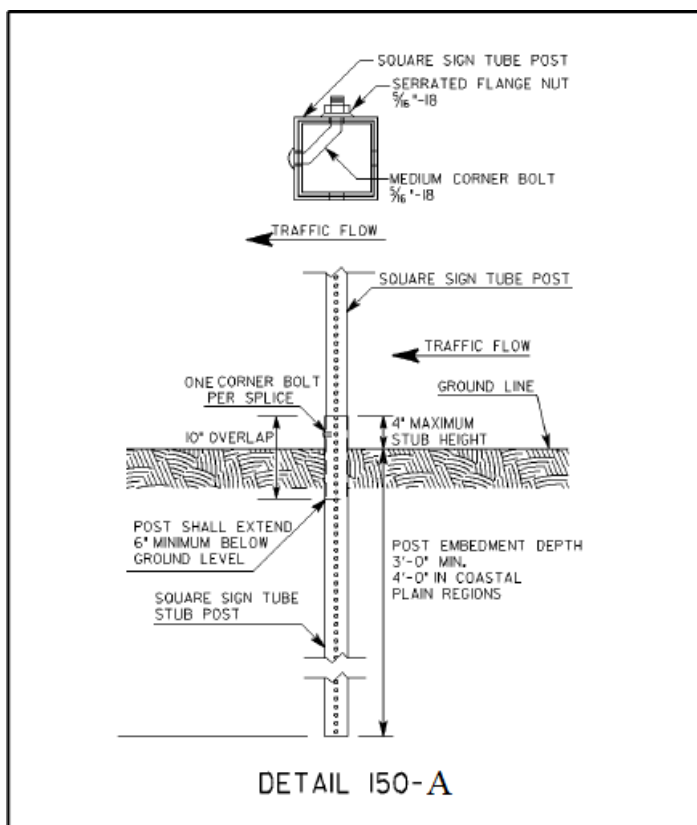

### B. Sign Blanks and Panels

All TTC sign blanks and panels should conform to Section 912 of the Specifications. Alternative sign blank materials (composites, polycarbonates, fiberglass reinforced plastics, recycled plastics, etc.) shall have a letter of approval from the Office of Materials and Testing for use as interim construction signs before these materials are allowed to be incorporated into the work, unless these rigid sign blanks are currently approved as a crashworthy sign blank material under QPL 34.

Unless specified elsewhere in the contract, specifications, plans, and/or directed by the Engineer, sign sizes are according to the following:

1. All construction signs sizes should follow the dimensions provide in MUTCD Table 6F-1 “Temporary traffic Control Zone Sign and Plaque Sizes” under the column for “Freeway or Expressway”.
2. For all other signs used just for staging, the sign sizes should follow the dimensions provide in MUTCD Table 2B-1 “Regulatory Sign and Plaque Sizes” for the largest size.
3. Permanent signs used for staging shall be according to plans.

Plywood blanks or panels will not be permitted. The use

of flexible signs will not be permitted.

For utility work not included in the contract, the utility contractor may use flexible signs within the project limits.

### **150.2.08 Pavement Markings**

All temporary traffic striping shall conform to the requirements of Section 652, Section 653, Section 657, Section 658, Section 659, and QPL-46.

#### **A. All Traffic Striping for 45 Days or Less ( $\leq 45$ Days)**

All traffic striping that will be in place for 45 days or less shall be 4 inches or greater in width.

#### **B. All Temporary Striping Beyond 45 days ( $>45$ Days)**

All traffic striping applied on intermediate surfaces shall be a minimum 5 inches in width or as shown on plans. On final surfaces when temporary striping will be overlaid or eradicated, the temporary striping shall be a minimum 5 inches in width.

#### **C. All Temporary Traffic Striping on Final Surface**

All temporary traffic striping applied to final surfaces which will not be overlay or grinded may be 4 inches in width or as shown on the plans.

### **150.2.09 Portable Changeable Message Signs**

Unless specified as a paid item in the contract, the use of a portable changeable message sign will not be required. When specified, a portable changeable message sign (PCMS) shall meet the minimum requirements of Section 632, MUTCD (6F.60) and be on QPL-82. The maximum amount of messages allowed to be flashed on one PCMS is two phases (flashes). The language and the timing of the messages shall comply with the MUTCD and Section 632. When used as an advanced device, the PCMS should typically be placed ahead of the construction activities. If the PCMS is used as a substitute for another device, then the requirements for the other device apply.

Any PCMS in use, which is not protected by positive barrier protection, shall be delineated by a minimum of three drums that meet the requirement of Subsection 150.2.04.B. The drum spacing shall not exceed a maximum of ten (10') feet as shown in Detail 150-B. When the PCMS is within twenty (20') feet of the opposing traffic flow, the trailing end of the PCMS shall be delineated with a minimum of three drums spaced in the same manner as the approach side of the PCMS.

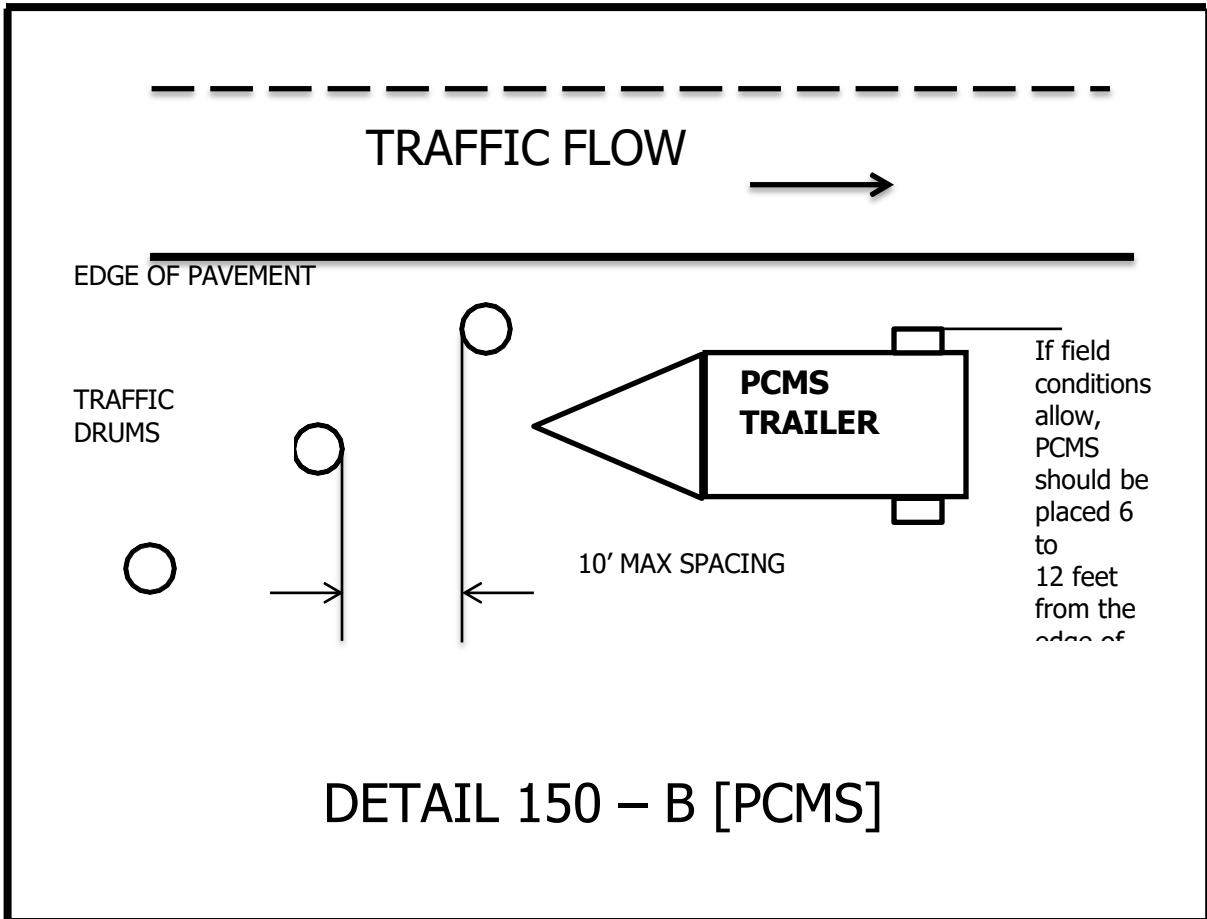

When not in use, the PCMS shall be removed from the roadway, unless protected by positive barrier protection. If the PCMS is protected by positive barrier protection, the sign panel shall be turned away from traffic when not in use.

**150.2.10 Portable Impact Attenuators**

This work consists of the furnishing (including spare parts), installation, maintenance, relocation, reuse as required, and removal of Portable Impact Attenuator Units/Arrays.

Portable Impact Attenuator Unit/Arrays installation shall conform to the requirements of Section 648, Manufacturer's recommendations and Georgia Standard 4960 "Temporary Barrier (End Treatment Options)" and shall be installed at locations designated by the Engineer, and/or as shown on the plans. When gating

attenuators are used, the contractor shall maintain the appropriate recovery area in accordance with the manufacturers' recommendations.

Generic sand/water loaded modules are prohibited. Manufacturers' sand/water loaded modules with specific arrays that have been NCHRP 350/MASH approved can be used in appropriate locations.

The test level of protection provided shall equal or exceed the speed limit. Test level 3 shall be used for forty-five (45) mph or above.

### **150.2.11 Portable Temporary Traffic Control Signals**

The use of Portable Temporary Traffic Control Signals shall meet the following minimum requirements: Only two-lane, two-way roadways will be allowed to utilize Portable Temporary Traffic Control Signals.

All portable traffic control signals shall meet the physical display and operational requirements of conventional traffic signals described in the MUTCD.

Each signal face shall have at least three lenses. The lenses shall be red, yellow, or green in color and shall give a circular type of indication. All lenses shall be twelve (12") inches nominal in diameter. A minimum of two signal faces shall face each direction of traffic. A minimum of one signal head shall be suspended over the roadway travel lane in a manner that will allow the bottom of the signal head housing to be not less than seventeen (17') feet above and not more than nineteen (19') feet above the pavement grade at the center of the travel lane. The second signal head may be located over the travel lane with the same height requirements or the second signal head may be located on the shoulder. When the signal head is located on the shoulder, the bottom of the signal head housing shall be at least eight (8') feet but not more than (15') feet above the pavement grade at the center of highway.

Advance warning signage and appropriate pavement markings shall be installed as part of the temporary signal operation.

The signals shall be operated in a manner consistent with traffic requirements. The signals may be operated in timed-mode or in a vehicle-actuated mode. The signals shall be interconnected in a manner to ensure that conflicting movements cannot occur. To ensure that the appropriate operating pattern, including timing is displayed to the traveling public, regular inspections, including the use of accurate timing devices shall be made by the Worksite Traffic Control Supervisor. If, at any time, any part of the system fails to operate within these requirements then the use of the signal shall be suspended and the appropriate flagging operation shall begin immediately.

The Worksite Traffic Control Supervisor (WTCS) shall continuously monitor the portable traffic control signal to insure compliance with the requirements for maintenance under the MUTCD. The signal shall be maintained in a manner consistent with the intention of the MUTCD, with emphasis on cleaning of the optical system. Timing changes shall be made only by the WTCS. The WTCS shall keep a written record of all timing changes.

The portable temporary signal shall have two power sources and shall be capable of running for seven calendar days continuously.

The Contractor shall have an alternate temporary traffic control plan in the event of failure of the signal.

### 150.2.12 Raised Pavement Markers

Raised pavement markers (RPMs) shall meet the requirements of Section 654 and QPL-76.

### 150.2.13 Rumble Strips

Rumble strips incorporated into the work shall meet the requirements of Section 429 and the MUTCD. Existing rumble strips that are positioned in the traveled way to warn traffic of a stop condition shall be reinstalled prior to opening to traffic. Based on the following requirements:

Intermediate surfaces that will be in use for more than forty-five (45) calendar days shall have rumble strips reinstalled on the traveled way in the area of a stop condition. Non-refundable deductions in accordance with Subsection 150.7.01 will be assessed for any intermediate surface in place for greater than 45 days without rumble strips.

Rumble strips shall be installed on the final surface within fourteen (14) calendar days of the placement of the final surface in the area of the stop condition. Failure to install within fourteen (14) calendar days will result in assessment of non-refundable deductions in accordance with Subsection 150.7.01.

Prior to the removal of any rumble strips located in the travel lane, stop ahead (W3-1) warning signs shall be double indicated ahead of the stop condition. These warning signs shall be a minimum of 48 inches by 48 inches. These warning signs shall remain in place until the rumble strips have been reinstalled on the traveled way. Any existing warning signs for the stop ahead condition shall be removed or covered while the 48" X 48" (W3-1) signs are in place. When the rumble strips have been reinstalled, these warning signs should be promptly removed and any existing signage placed back in service.

### 150.2.14 Temporary Barriers

#### A. Design:

Temporary barriers shall meet the requirements of Sections 620. The lengths of advancement should be in accordance with Georgia Standard 4000W "Lengths of Advancement, Clear Zone Distances, and Fill Height Embankment". The approach end of the taper should have 10:1 or flatter ground slope. Temporary barriers shall not be used as a channelization device. Their use is in accordance with MUTCD (6F.85).

#### B. Application:

Temporary barriers shall be placed as required by the plans, standards, and as directed by the Engineer. When Temporary barrier is located twenty feet ( $\leq 20'$ ) or less from a travel lane, yellow reflectors shall be fixed to the top of the barrier at intervals not greater than forty feet ( $\leq 40'$ ) in the longitudinal section and twenty feet ( $20'$ ) in the taper section and shall be mounted approximately two inches (2") above the barrier. If both lanes of a two-lane two-way roadway are within twenty feet ( $\leq 20'$ ) or less of the barrier then the reflectors shall be installed for both directions of traffic.

The reflectors shall be hundred (100) square inches (ASTM Type VII or VIII/ Type XI) reflective sheeting mounted on flat-sheet blanks. The reflectors shall be mounted approximately two inches above the top of the barrier. The reflectors shall be attached to the barrier with adhesive or by a drilled-in anchor type device. The reflectors shall not be attached to a post or board that is placed between the gaps in the barrier sections.

Approach end of Temporary barrier shall be protected according to Georgia Standard 4960 “Temporary Barrier (End Treatment Options)” or by a portable impact attenuator.

On interstates or other controlled access highways where lane shifts or crossovers cause opposing traffic to be separated by less than forty feet (<40’), portable barrier should be used as a separator.

#### **150.2.15 Temporary Guardrail Anchorage- Type 12**

This work consists of the furnishing, installation, maintenance and removal of Temporary Guardrail Anchorage- Type 12 used for Portable Barrier or temporary guardrail end treatment. Materials used in the Temporary Guardrail Anchorage- Type 12 shall meet the requirements of Section 641 of the Specifications and current Georgia Standards and may be new or used. Materials salvaged from the Project, which meet the requirements of Standards, may be utilized if available. The use of any salvaged materials will require prior approval of the Engineer.

Installation of the Temporary Guardrail Anchorage- Type 12 shall conform to the requirements of the Plans, current Georgia Standards and Section 641 of the Specifications. Installation shall also include sufficient additional guardrail and appurtenances to effect the transition and connection to Temporary Concrete Barrier as required by the details in Georgia Standard 4960 “Temporary Barrier (End Treatment Options)”.

#### **150.2.16 Temporary Traffic Signals**

Temporary traffic signals shall meet the requirements of Section 647 and the MUTCD.

### **150.3 Construction Requirements**

#### **150.3.01 General**

##### **A. Implementation Requirements**

No work shall be started on any project phase until the appropriate traffic control devices have been placed in accordance with the Project requirements. Changes to traffic flow shall not commence unless all labor, materials, and equipment necessary to make the changes are available on the Project.

When any shift or change is made to the location of traffic or to the flow patterns of traffic, including pedestrian traffic, the permanent safety features shall be installed and fully operational before making the change. If staging or site conditions prevent the installation of permanent features then the equivalent interim devices shall be utilized. This work shall also include any necessary removal and reinstallation of guardrail panels to achieve the required panel lap to accommodate the appropriate shift and traffic flow including the final traffic flow configuration. The cost of performing this work shall be included in Traffic Control-Lump Sum.

Any section of the work that is on a new location shall have all permanent safety features installed and fully operational before the work is opened to traffic. Safety features shall include, but are not limited to the following items:

- 1) Guardrails including anchors and delineation with properly lapped panels
- 2) Cable Barrier
- 3) Impact attenuators
- 4) Traffic signals
- 5) Warning devices
- 6) Pavement markings including words, symbols, stop bars, and crosswalks
- 7) Roadway signs including regulatory, warning, and guide

Outdoor lighting shall be considered as a safety feature for welcome centers, rest areas, and weigh station projects. For typical roadway type projects, new street lighting is not considered a safety feature, unless specifically noted in the plans or in the special conditions.

## **B. Maintenance of Traffic Control Devices**

Traffic control devices shall be in acceptable condition when first erected on the project and shall be maintained in accordance with Section 104 throughout the construction period. All unacceptable traffic control devices shall be replaced within twenty-four (24) hours. When not in use, all traffic control devices shall be removed, placed or covered so as not to be visible to traffic. All construction warning signs shall be removed within seven (7) calendar days after time charges are stopped or pay items are complete. If traffic control devices are left in place for more than ten (10) calendar days after completion of the Work, the Department shall have the right to remove such devices, claim possession thereof, and deduct the cost of such removal from any monies due, or which may become due, the Contractor.

## **C. Traffic Interruption Restrictions**

The Department reserves the right to restrict construction operations when, in the opinion of the Engineer, the continuance of the Work would seriously hinder traffic flow, be needlessly disruptive or unnecessarily inconvenience the traveling public. The Contractor shall suspend and/or reschedule any work when the Engineer deems that conditions are unfavorable for continuing the Work.

Advanced notification requirements to the Contractor to suspend work will be according to the events and the time restrictions outlined below:

Incident management - No advanced notice required

Threatening/Inclement weather – twenty-four (24) hours

Holiday, sporting events, unfavorable conditions - Three (3) calendar days

If the work is suspended, the Contractor may submit a request for additional contract time as allowed under Section 108. The Department will review the request and may grant additional contract time as justified by the impact to the Contractor's schedule. Compensation for loss of productivity, rescheduling of crews, rental of equipment or delays to the Contractor's schedule will not be considered for payment. Additional contract time will be the only consideration granted to the Contractor.

## **D. Work Zone Restrictions**

### **1. Interstate**

The Contractor should not simultaneously perform work on both the inside shoulder and outside shoulder on either direction of traffic flow when the Work is within 12 feet of the travel-way. Shoulders can be alternated if areas are separated by at least one-half mile of distance.

## 2. Non-Interstate Divided Highways

The Contractor should not simultaneously perform work on both the inside shoulder and outside shoulder on either direction of traffic flow when the Work is within 12 feet of the travel-way. Shoulders can be alternated if areas are separated by at least one-half mile distance in rural areas or at least 500 feet of distance in urban areas.

## 3. Non-Divided Highways

- a. The Contractor should not simultaneously perform work on opposite sides of the roadway when the work is within 12 feet of the travel-way. Shoulders can be alternated if areas are separated by at least one-half mile of distance in rural areas or at least 500 feet of distance in urban areas.
- b. On two-lane projects where full width sections of the existing subgrade, base or surfacing are to be removed, and new base, subgrade, or surfacing are to be constructed, the Contractor should maintain one-lane traffic through the construction area by removing and replacing the undesirable material for half the width of the existing roadway at a time. Replacement should be made such that paving is completed to the level of the existing pavement in the adjacent lane by the end of the workday or before opening all the roadway to traffic.

### E. Work Zone Geometric Restrictions

There should be no reduction in the total number of available traffic lanes including turning lanes that existed prior to construction, except as specifically allowed by the Contract and as approved by the Engineer.

Travel lane Clearances: All portions of the work should maintain the following minimum requirements:

Horizontal: The combined dimensions of the paved shoulder and the roadway surface remaining outside the Work Zone should be no less than sixteen feet ( $\geq 16'$ ) in width at any location.

Vertical: The overhead clearance should not be reduced to less than fifteen feet ( $\geq 15'$ ) at any location.

The restrictions above apply to all shifts, lane closures, on-site detours and off-site detours whether shown in the contract or proposed by the Contractor. It shall be the responsibility of the Contractor to verify that these minimum requirements have been met before proceeding with any phase of the Work. Two-lane, two-way roadways may have temporary horizontal restrictions of less than sixteen feet ( $\geq 16'$ ) during flagging operations. The minimum horizontal clearance should be restored before the flagging operation is removed.

### F. Clear Zone

At the end of the workday, all equipment, materials, and TTC devices not in use should be moved out of the clear zone or behind positive protection. The clear zone is defined by Georgia Standard 4000W "Lengths of Advancement, Clear Zone Distances, Fill Height Embankment". For urban roadway with curb, the minimum set back is six (6') feet from the curb face. If stored behind positive protection, proper lengths of advancement should be maintained. If stored behind guardrail the items shall be a minimum five feet ( $\geq 5'$ ) from the face of the guardrail and not in the recovery zone of the anchor.

The Worksite Traffic Control Supervisor (WTCS) shall monitor the work to ensure that all the rocks, boulders, construction debris, stockpiled materials, equipment, tools and other potential hazards are kept clear of the travel lane.

### **G. Milled Surface Restrictions**

Unless modified by the special conditions, a milled surface on any asphaltic concrete surface shall not be allowed to remain open to traffic for a period of time that exceeds thirty (> 30) calendar days.

### **H. Construction Vehicles**

The Contractor's vehicles shall travel in the direction of normal roadway traffic and shall not reverse direction except at intersections, interchanges, or approved temporary crossings. The Contractor may submit a plan requesting that construction traffic be allowed to travel in the opposite direction of normal traffic when it would be desirable to modify traffic patterns to accommodate specific construction activities.

Prior approval of the Engineer shall be obtained before any construction traffic is allowed to travel in a reverse direction. If the Contractor's submittal is approved, the construction traffic shall be separated from normal traffic by appropriate traffic control devices.

The parking of Contractor's and/or workers' personal vehicles within the work area or adjacent to traffic is prohibited. It shall be the responsibility of the Worksite Traffic Control Supervisor to ensure that any vehicle present at the worksite is necessary for the completion of the work.

### **I. Environmental Impacts**

The Contractor shall ensure that dust, mud, and other debris from construction activities do not interfere with normal traffic operations or adjacent properties.

### **J. Existing Street Lights**

Existing street lighting shall remain lighted as long as practical and until removal is approved by the Engineer.

### **K. Nighttime Work Lighting**

Adequate temporary lighting shall be provided at all nighttime work sites where workers will be immediately adjacent to traffic.

### **L. Removal/Reinstallation of Miscellaneous Items**

In the prosecution of the Work, if it becomes necessary to remove any existing signs, markers, guardrail, etc. not covered by specific pay item, they shall be removed, stored and reinstalled, when directed by the Engineer, to line and grade, and in the same condition as when removed.

### **150.3.02 Personnel – Worker Safety Apparel**

In accordance with MUTCD (6D.03) all workers, within the right-of-way who are exposed either to traffic or to work vehicles and construction equipment within the TTC zone, shall wear high-visibility safety apparel that meets the Performance Class 2 or better.

### **150.3.03 Signage - General**

#### **A. Signing Requirements of the Temporary Traffic Control (TTC) Plan**

When existing regulatory, warning or guide signs are required for proper traffic and pedestrian control, the Contractor shall maintain these signs in accordance with the temporary traffic control (TTC) plan. The Contractor shall review the status of all existing signs, interim signs added to the work, and permanent sign installations that are part of the work to eliminate any conflicting or non-applicable signage in the TTC Plan. The Contractor's review of all signs in the TTC Plan shall establish compliance with the requirements of the MUTCD and Section 150. Any conflicts shall be reported to the Engineer immediately and the WTCS shall take the necessary measures to eliminate the conflict.

The Contractor shall make every effort to eliminate the use of interim signs as soon as the Work allows for the installation of permanent signs.

All existing illuminated signs shall remain lighted and be maintained by the Contractor. Existing street name signs shall be maintained at street intersections.

Refer to section **150.2.05.B. Sign Blanks and Panels** for size and material requirements.

#### **B. Conflicting or Non-Applicable Signs**

Any sign(s) or portions of a sign(s) that are not applicable to the TTC plan shall be covered so as not to be visible to traffic or shall be removed from the roadway when not in use. The WTCS shall review all traffic shifts and changes in the traffic patterns to ensure that all conflicting signs have been removed. The review shall confirm that the highest priority signs have been installed and that signs of lesser significance are not interfering with the visibility of the high priority signs. High priority signs include signs for road closures, shifts, detours, lane closures and curves. Any signs, such as speed zones and speed limits, passing zones, littering fines and litter pick up, that reference activities that are not applicable due to the presence of the Work shall be removed, stored and reinstalled when the Work is completed.

Failure to promptly eliminate conflicting or non-applicable signs shall be considered as non-performance under Subsection 150.7.01.

#### **C. Removal of Existing Signs and Supports**

The Contractor shall not remove any existing signs and supports without prior approval from the Engineer. All existing signs and supports which are to be removed shall be stored and protected if this material will be required later in the work as part of the TTC plan. If the signs are not to be utilized in the work then the signs will become the property of the Contractor unless otherwise specified in the contract documents.

#### **D. Interim Guide, Warning and Regulatory Signs**

Interim guide, warning, or regulatory signs required to direct traffic and pedestrians shall be furnished, installed, reused, and maintained by the Contractor in accordance with the MUTCD, the Plans, Special Provisions, Special Conditions, or as directed by the Engineer. These signs shall remain the property of the Contractor. When the signs are used for long-term stationary operations as defined MUTCD (6G.02), the bottom of all interim signs shall be mounted seven feet (7') to eight feet (8') above the level of the pavement edge or sidewalk. The signs offset should be six feet (6') to twelve feet (12') from the pavement edge or two feet ( $\geq 2'$ ) minimum for sidewalks according to MUTCD (6F-1). Special Conditions under Subsection 150.6 may modify this requirement.

Portable signs may be used when the duration of the work is less than three (3) days or as allowed by the special conditions in Subsection 150.6. Portable signs shall be used for all punch list work. Portable interim signs shall be mounted a minimum of one foot ( $\leq 1'$ ) above the level of the pavement edge for directional traffic of two (2) lanes or less and at seven feet (7') for directional traffic of three (3) or more lanes according to MUTCD (6F- 2). Signs shall be mounted at the height recommended by the manufacturer's crashworthy testing requirements.

All sign blanks shall be rigid whether the sign is mounted as a portable sign, on a Type III barricade or as a permanent mount height sign. Utilities and their subcontractors working in the project limits, and not included in the project contract, may use non-rigid signs.

## **E. Existing Special Guide Signs**

Existing special guide signs on the Project shall be maintained until conditions require a change in location or legend content. When change is required, existing signs shall be modified and continued in use if the required modification can be made within existing sign borders using design requirements (legend, letter size, spacing, border, etc.) equal to that of the existing signs, or of Subsection 150.3.E.2. Differing legend designs shall not be mixed in the same sign.

### **1. Special Guide Signs**

Special guide signs are those expressway or freeway guide signs that are designed with message content (legend) that applies to a particular roadway location. When an existing special guide sign is in conflict with work to be performed, the Contractor shall remove the conflicting sign and reset it in a new, non- conflicting location which has been approved by the Engineer.

### **2. Interim Special Guide Signs**

When it is not possible to utilize existing signs, either in place or relocated, the Contractor shall furnish, erect, maintain, modify, relocate, and remove new interim special guide signs in accordance with the Plans or as directed by the Engineer. Interim special guide signs that may be required in addition to, or a replacement for, existing expressway and freeway (interstate) signs shall be designed and fabricated in compliance with the minimum requirements for guide signing contained in Part 2E "Guide Signs – Freeway and Expressway" of the MUTCD. All interstate shields on these signs shall be 48 inches and 60 inches for two-numeral and three-numeral routes, respectively.

The road name of the exit or route shield shall be placed on the exit gore sign.

### **3. Interim Overhead Guide Sign Structures**

Interim overhead special guide sign structures are not required to be lighted unless specifically required by the Plans. If lighting is required, the sign shall be lighted as soon as erected and shall remain lighted, during the hours of darkness, until the interim sign is no longer required. The Contractor shall notify the Power Company at least thirty (30) days prior to desire connection to the power source.

### **4. Permanent Special Guide Signs**

The installation of new permanent special guide signs and the permanent modification or resetting of existing special guide signs, when included in the contract, shall be accomplished as soon as practical to minimize the use of interim special guide signs. If lighting is required by the Plans, all new permanent overhead special guide signs shall be lighted as soon as erected.

## **F. Stop Sign Regulated Intersections**

For intersections that utilize stop sign(s) to control the flow of traffic and to restrict the movement of vehicles, the stop sign(s) shall be maintained for the duration of the work or until such time that the stop condition is eliminated or until an interim or permanent traffic signal can be installed to provide proper traffic control. The traffic signal shall be installed and properly functioning before the removal of the existing stop sign(s) is permitted. If the existing intersection is enhanced traffic control features, such as stop lines, double indicated stop signs, oversized signs, advanced warning stop ahead signs, rumble strips on the approaches or flashing beacons located overhead or on the shoulders then these features shall be maintained for the duration of the project or until the permanent traffic control plan has been implemented.

Whenever the staging of the work requires that the traveled way be relocated or realigned the Contractor shall reinstall all enhanced traffic control features noted above on the newly constructed sections of the work. The cost of relocating the stop lines, stop signs, advanced warning signs, the rumble strips and the flashing beacons shall be included in the price bid for Traffic Control - Lump Sum unless individual pay items are included in the contract for rumble strips and/or flashing beacons. When pay items are included in the contract for rumble strips or flashing beacons then these items will be paid per each.

When staging requires the relocation or realignment of an existing stop condition, it may be necessary to consider the addition of enhanced traffic control features even though none existed at the original location. Horizontal and vertical alignment changes at a new location may have decreased or restricted sight distance or the stop condition may occur sooner than in the previous alignment. If these conditions occur, then the Engineer and/or the WTCS should consider additional measures to enhance the motorist's awareness of the changes even though the staging plans may not address enhanced features. Stop signs should be a minimum of 36 inches for interim situations. The use of 48 inch stop signs may be warranted under project specific conditions. Flags may be used on interim/permanent stop signs that are mounted at seven (7') feet in height for a short duration in order to direct additional attention to a new or relocated stop sign(s). Flags should not be used for durations exceeding two weeks unless unusual or site specific conditions warrant a longer period of time. The use of Type "A" flashing red light(s) attached to the stop sign(s) may be appropriate during the same period that the flags are in use to increase attention.

The use of rumble strips and/or portable changeable message signs may be considered. The use of new rumble strips, where none previously existed, shall have the prior approval of District Traffic Operations before being included as part of the temporary traffic control plan. The message(s) displayed on any PCMS shall have the prior approval of the Engineer and the message(s) shall be included as part of the TTC plan for the interim staging.

The placement of any additional interim ground mounted signs and posts or stop lines shall be considered as incidental to the price bid for Traffic Control - Lump Sum. The installation of rumble strips, flashing beacons or the use of Portable Changeable Message Signs (PCMS) shall be considered as Extra Work unless pay items are included in the contract.

## **G. Low Shoulder Signage**

### **1. Low Shoulder for Construction/Reconstruction/Resurfacing Projects**

"Low Shoulder" (W8-9) signs shall be erected when a difference in elevation less than four (< 4') feet from the traveled way, exceeds one inch (> 1") but does not exceed three inches ( $\leq 3$ ") between the travel lane and any type of shoulder.

The spacing of the signs shall not exceed one (1) mile and the signs shall be placed immediately past each crossroad intersection. The "Low" signs shall remain in place until the difference in elevation is eliminated and the shoulder has been dressed and permanently grassed for a minimum of thirty (30) calendar days. These signs shall be furnished, installed, maintained and removed by the Contractor as part of Traffic Control-Lump Sum. These signs shall be fluorescent orange with black borders.

## 2. Shoulder Drop-Off for Construction/Reconstruction/Resurfacing Project

“Shoulder Drop-Off” (W8-17) signs shall be used when a difference in elevation, less than four feet (< 4’) from the traveled way, exceeds three inches (> 3”) and is not protected by positive barrier protection. These warning signs shall be placed in advance of the drop-off.

The spacing of the signs shall not exceed one (1) mile and the signs shall be placed immediately past each crossroad intersection. The “Shoulder Drop-Off” signs shall remain in place until the difference in elevation is eliminated and the shoulder has been dressed and permanently grassed for a minimum of thirty (30) calendar days. These signs shall be furnished, installed, maintained, and removed by the Contractor as part of Traffic Control-Lump Sum. These signs shall be black borders on fluorescent orange background.

### H. Bump Signage

A bump sign (W8-1) shall be utilized when a transverse joint in the pavement structure has a vertical difference in elevation of three quarters ( $\geq 3/4$ ”) of an inch or greater in depth with no horizontal taper to ramp the traffic from one elevation to the other. This condition typically occurs at approach slabs during pavement milling operations and at transverse joints in asphaltic pavement lifts. Other conditions include utility and storm drainage repairs that require concrete placement for patching and/or steel plating.

The W8-1 sign shall be placed sufficiently in advance to warn the motorist of the condition.

### I. Sign Visibility

All existing, interim and new permanent signs shall be installed so as to be completely visible and legible for an advance distance in compliance with the MUTCD. Any clearing required for maintaining the line of sight to existing, interim or permanent signs shall be done as part of the requirements of the TTC plan. The clearing shall include any advance warning signs, both interim and permanent, that are installed as a part of the work including advance warning signs that are installed outside the limits of the project. Limbs, brush, construction equipment and materials shall be kept clear of the driver’s line of sight to all signs that are part of the TTC plan.

## 150.3.04 Advance Warning Signs

### A. Project Signs - All Type of Highways

Advance warning signs shall be placed ahead of the work area in accordance with Part 6 of the MUTCD and shall include a series of at least three advance road work (W20-1) signs placed at the termini of the project. The series shall have the legend ROAD WORK (1500 FEET, 1000 FEET, AND 500 FEET).

At grade intersecting roadways and on-ramps shall be signed with a minimum of one ROAD WORK AHEAD sign.

When work terminates at a “T” intersection, a minimum of one “ROAD WORK AHEAD” sign shall be placed in advance of the intersection and one “END ROAD WORK” sign shall be placed at the termination end of the intersection. Field conditions may require the use of additional warning signage.

#### 1. State Routes

Advanced Warning Signs on State Routes shall be a minimum dimension of forty-eight inches by forty- eight inches (48” x 48”). When a State Route intersects a project which consists of adding travel lanes, reconstructing an existing roadway or new location work, the State Route approaches shall have a

minimum of three (W20-1) advanced warning signs (1500 ft., 1000 ft., 500 ft.). The termination end of an intersecting State Route shall have END ROAD WORK signage.

The W20-1 signs shall be placed at the termini of the project or sufficiently in advance of the termini to allow for lane shifts, lane closures and other activities which may also require advanced warning signs. The advanced warning signs for the project should not overlap with the advanced warning signs for lane shifts, lane closures, etc.

The length of a work zone should be held to the minimum length required to accomplish the work. If a project has multiple individual worksites within the overall limits of the project, each site should be signed individually if the advance warning signs for each site can be installed without overlapping an adjacent worksite. As soon as the work is completed at any individual site, the warning signs shall be removed from that site. Clean-up work and punch list work shall be performed with portable signage.

Project mileage indicated on the G20-1 sign shall be the actual project mileage rounded up to the nearest whole mile. Projects less than two (< 2) miles in length or individual worksites that are part of a multiple worksite project may delete this sign. The G20-1 sign shall be forty-eight inches by twenty-four inches (48" x 24") and the G20-2 sign shall be forty-eight inches by twenty-four inches (48" x 24").

## 2. Interstate, Limited Access and Multilane Divided Highways

In addition to the W20-1 signs required at 500 ft., 1000 ft. and 1500 ft., multi-lane divided highways shall also have additional advanced warning signs installed with the legend "ROAD WORK (2 MILES, 1 MILE and 1/2 MILE). All construction warning signs on divided highways shall be double indicated (i.e., on the left and right sides of the roadway.) If the use of the half (½) mile, one (1) mile and two (2) mile advanced warning signs cause an overlap with other work or do not benefit field conditions then the Engineer may review the use of these signs and eliminate their installation. When the posted speed limit is fifty (≤ 50) mph or less, the one-half (½) mile, one (1) mile and two (2) mile signs should be eliminated especially in urban areas.

The W20-1 advance warning signs for ROAD WORK 500 FEET; 1000 FEET; and 1500 FEET shall be temporarily covered when work involving the advanced warning signs for lane shifts and lane closures overlap these signs. The ROAD WORK ½ MILE, ROAD WORK 1 MILE, and ROAD WORK 2 MILES shall be in place when the 500, 1000 and 1500 feet signs are temporarily covered.

When the temporary traffic control zone already has advanced warning (W20-1) signs installed the W20-1 signs required for lane closures under Standard 9106 should be eliminated.

## 3. Ramp Work on Limited Access Highways

The work zone shall not be signed for the entire length of the mainline of a limited access highway when only short individual worksites, interchange or ramp work is being performed.

When work is restricted to ramp reconstruction or widening activities, the advance warning signs on the mainline section of the limited access highway shall be limited to the use of portable advance warning signs. These portable advance warning signs shall only be utilized when work activity is within the gore point of the ramp and the mainline traveled way or work is active in the acceleration/deceleration lane adjacent to the mainline traveled way. Portable advance warning signs (W20-1: 1500 ft. /1000 ft. /500 ft.) shall be installed on the traveled way of the limited access highway when the above conditions are present. The advance warning signs shall be installed only in one direction where work is active. All portable signs shall be double indicated. When work is not active, the ramp work shall be advanced warned by the use of a single forty-eight inches by forty-eight inches (48" x 48") "ROAD WORK AHEAD" (W20-1) with an "ON RAMP" plaque (W13-4p) sign along the right shoulder of the mainline traveled way prior to the beginning of the taper for the deceleration lane. Differences in elevation shall be in compliance with the requirements of Subsection 150.3.11 prior to the removal of the portable (W20-1) advanced warning signs from the mainline.

## B. Highway Work Zone

In accordance with Georgia Code, O.C.G.A. § 40-6-188, all sections or segments of the roadway under construction or reconstruction shall be signed as a Highway Work Zone except non-state highway two-lane two-way resurfacing projects. Two conditions can be applied to a Highway Work Zone. Condition 1 is when no reduction in the existing speed limit is required. Condition 2 is when worksite conditions require a reduction of the speed limit through the designated Work Zone. Properly marking a Highway Work Zone shall include the following minimum requirements:

### 1. No Reduction in the Existing Posted Speed Limit in Highway Work Zone

- a. Signage shall be posted at the beginning point of the Highway Work Zone warning the traveling public that increased penalties for speeding violations are in effect. The beginning point of Highway Work Zone is at the project limits, start of work zone, or at the start of the first taper. The HWZ-2 sign shall be placed a minimum of 600 feet in advance of the Highway Work Zone and shall not be placed more than 1000 feet in advance of the Work Zone. If no speed reduction is required, it is recommended that the HWZ-2 be placed at 750 feet from the work area between the ROAD WORK 500 FT. and the ROAD WORK 1000 FT. signs.

HWZ-2 signs shall be placed at intervals not to exceed one mile for the length of the project. HWZ-2 signs should be placed on the mainline after all major intersections except State Routes. State Routes shall be signed as per the requirements for intersecting roadways below.

- b. The existing speed limit shall be posted at the beginning of the Work Zone. Existing Speed Limit signs (R2-1) shall be maintained.
- c. Intersecting state routes shall be signed in advance of each intersection with the Work Zone with a HWZ-2 sign to warn motorists that increased fines are in effect. All other intersecting roadways that enter into a designated Highway Work Zone may be signed in advance of each intersection with the Work Zone. When construction equipment and personnel are present in the intersection on the mainline of a multi-lane roadway, the intersecting side roads shall be signed in advance with HWZ-2 signs. As soon as the work operation clears the intersection, the signage may be removed.
- d. Sign HWZ-3 shall be posted at the end of the Highway Work Zone indicating the end of the zone and indicating that increased penalties for speeding violations are no longer in effect.
- e. When a designated Highway Work Zone is no longer necessary, all signs shall be removed immediately.

### 2. Reducing the Speed Limit in a Highway Work Zone

Highway Work Zone signs shall be posted as required in Condition 1 above in accordance with Detail 150-C.

A “Reduce Speed Limit Ahead” (W3-5) sign shall be posted 600 feet prior to the reduced speed limit.

Then a “Speed Limit” signage (R2-1) for the reduced speed limit shall be erected at the beginning of the work zone. Additional signs shall be placed at whichever is least:

- a. on non-interstate roads after every junction with a numbered (state or U.S.) route.
- b. on interstates entrance ramp 1,500 feet from the end of the entrance taper. Detail 150-D
- c. on non-interstate and interstate a maximum spacing of no greater than one (1) mile apart.

On multi-lane divided highways, the speed limit signs shall be double indicated when the reduced speed is in use.

Additional signs may be necessary to adjust for actual field conditions.

For limited access (interstate) highways and controlled access multi-lane divided highways, the posted speed limit shall be reduced as required below.

When any one or more of the following conditions exist and the existing speed limit is sixty-five (65) mph or seventy (70) mph, the speed limit shall be reduced by ten (10) mph. If the existing speed limit is sixty (60) mph, the speed limit should be reduced by five (5) mph. If the existing speed limit is fifty-five ( $\leq 55$ ) mph or less, the Contractor can only reduce the speed limit with the prior approval of the Engineer. The reduction in the speed limit shall be no greater than ten (10) mph:

- a) Lane closure(s) of any type and any duration.
- b) The difference in elevation exceeds two inches ( $> 2''$ ) adjacent to a travel lane as shown in Subsection 150.3.11, Detail 150-E, Detail 150-F.
- c) Any areas where equipment or workers are within ten feet (10') of a travel lane.
- d) Temporary portable concrete barriers located less than two feet (2') from the traveled way.
- e) As directed by the Engineer for conditions distinctive to this project.

When the above conditions are not present, the speed limit shall be immediately returned to the existing posted speed limit. A speed reduction shall not be put in place for the entire length of the project unless conditions warranting the speed reduction are present for the entire project length. All existing speed limit signs within the temporary speed reduction zone shall be covered or removed while the temporary reduction in the speed limit is in effect. All signs shall be erected to comply with the minimum requirements of the MUTCD.

At a minimum, the following records shall be kept by the WTCS:

- a) Identify the need for the reduction.
- b) Record the time of the installation and removal of the temporary reduction.
- c) Fully describe the location and limits of the reduced speed zone.
- d) Document any accident that occurs during the time of the reduction.

A copy of the weekly records for reduced speed zones shall be submitted to the Engineer.

When a pilot vehicle is used on a two-lane two-way roadway, the speed limit should not be reduced. For special conditions specific to the work, on two-lane two-way roadways or multi-lane highways, the contractor may reduce the posted speed limit with the prior approval of the Engineer.

### 3. Variable Speed Limit Zones

Projects that are within or extends into variable speed limit zones shall be posted according to condition 1 with HWZ-1, HWZ-2, and HWZ-3 signs. No additional "speed limit" signs, (R2-1), shall be posted. Any reduction or increase in speed limits will be controlled by the normal operation of the variable speed limit system.

Upon request, a maximum speed limit of fifty-five (55) mph can be set for the project limits.

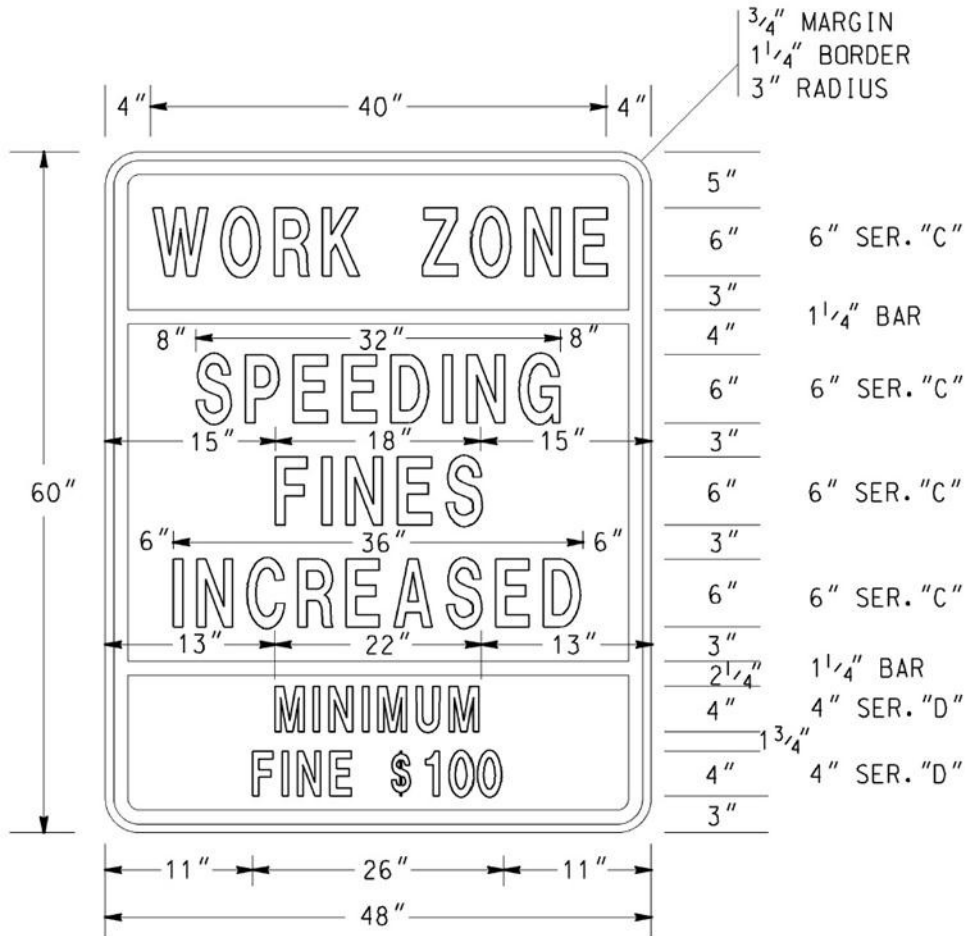

HWZ-2

COLORS  
TOP PANEL

LEGEND & BORDER - BLACK (NON-REFL)  
BACKGROUND - FLUORESENT ORANGE

MIDDLE & BOTTOM PANELS

LEGEND & BORDER - BLACK  
BACKGROUND - WHITE

NOTES:

1. ALL HWZ-2 SIGN PANELS SHALL BE RIGID.
2. THE SIZE OF THE HWZ-2 SIGN SHALL NOT BE REDUCED FOR USE ON TWO-LANE ROADWAYS.

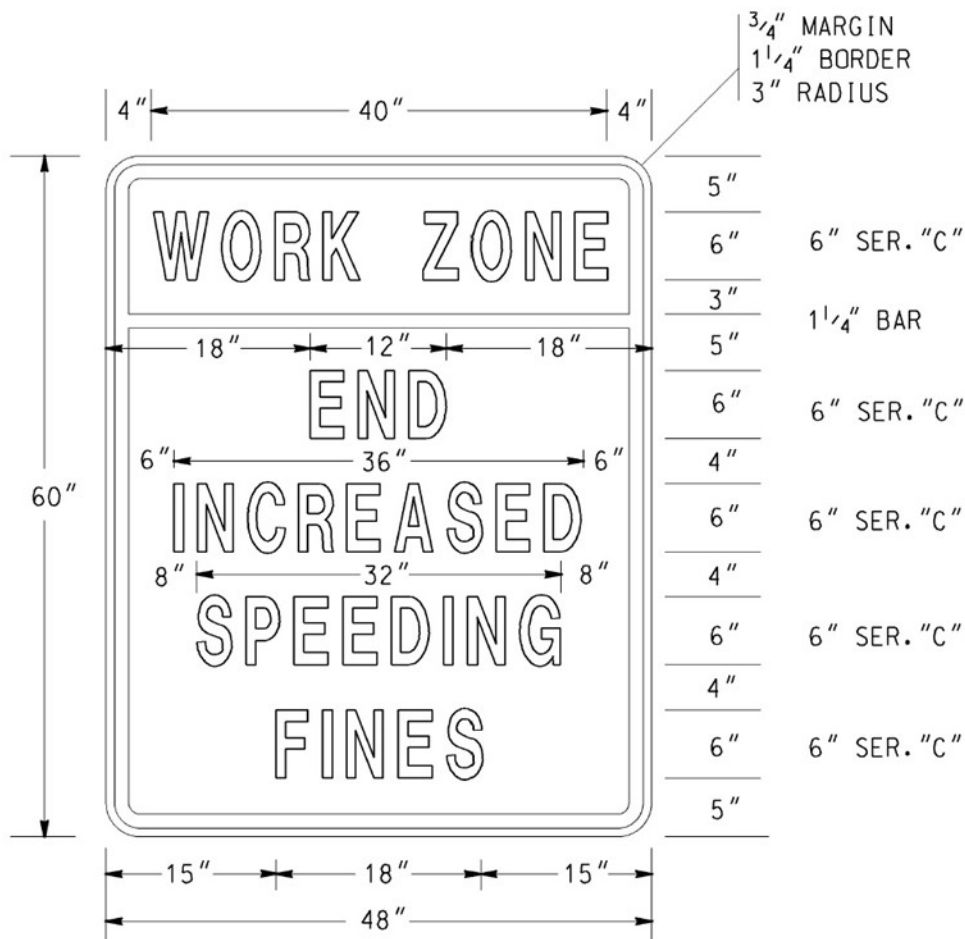

HWZ-3

COLORS

TOP PANEL

LEGEND & BORDER - BLACK (NON-REFL)  
BACKGROUND - FLUORESENT ORANGE

BOTTOM PANEL

LEGEND & BORDER - BLACK (NON-REFL)  
BACKGROUND - WHITE

NOTES:

1. ALL HWZ-3 SIGN PANELS SHALL BE RIGID.
2. THE SIZE OF THE HWZ-3 SIGN SHALL NOT BE REDUCED FOR USE ON TWO-LANE ROADWAYS.

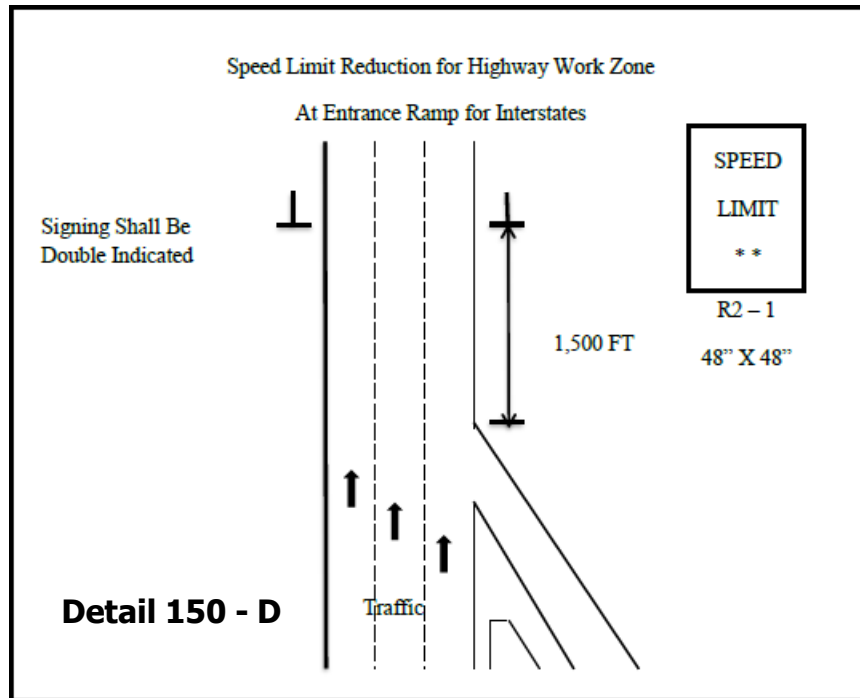
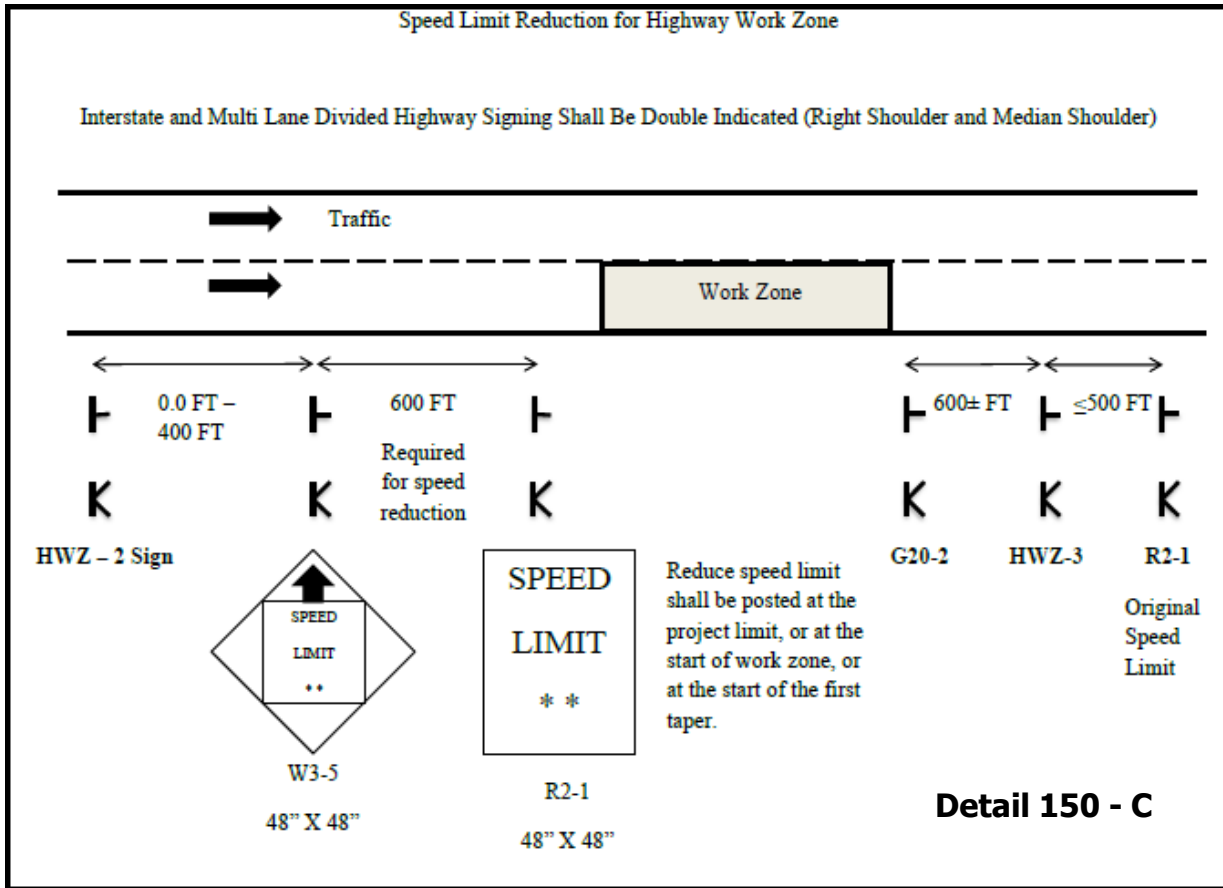

### C. Installation/Removal of Work Area Signage

No payment will be made for Traffic Control-Lump Sum until the Work has actually started on the project. The installation of traffic control signage does not qualify as the start of work. Advanced warning signs shall not be installed until the actual beginning of work activities. Any permanent mount height signs installed as the work is preparing to start shall be covered until all signs are installed unless all signs are installed within seven ( $\leq 7$ ) calendar days after beginning installation.

All temporary traffic control devices shall be removed as soon as practical when these devices are no longer needed. When work is suspended for short periods of time, temporary traffic control devices that are no longer appropriate, shall be removed or covered.

All construction warning signs shall be removed within seven ( $\leq 7$ ) calendar days after time charges are stopped or pay items are complete. If traffic control devices are left in place for more than ten ( $> 10$ ) calendar days after completion of the Work, the Department shall have the right to remove such devices, claim possession thereof, and deduct the cost of such removal from any monies due, or which may become due, the Contractor.

PUNCH LIST WORK: Portable signs shall be utilized to accomplish the completion of all punch list items. The portable signs shall be removed daily. All permanent mount height signs shall be removed prior to the beginning of the punch list work except "Low/Soft Shoulder" signs and any signs that have the prior written approval of the Engineer to remain in place while the punch list work is in progress.

Failure to promptly remove the construction warning signs within the seven (7) calendar days after the completion of the Work or failure to remove or cover signs when work is suspended for short periods of time shall be considered as non-performance under Subsection 150.7.01.

## 150.3.05 Shoulder/Lane Closures

### A. Approval/Restrictions

All shoulder closures and lane closures of any type or duration shall have the prior approval of the Engineer.

#### 1. Closure Length

The length of a shoulder closure and a lane closure shall not exceed two (2) miles in length excluding the length of the tapers unless the prior approval of the Engineer has been obtained. The Engineer may extend the length of the closure based upon field conditions; however, the length of a work zone should be held to the minimum length required to accomplish the Work. Shoulder closure and Lane Closures shall not be spaced closer than one mile. The advanced warning signs for the project should not overlap with the advanced warning signs for lane shifts, lane closures, etc.

#### 2. Duration

The first three (3) calendar days of any lane closure shall be signed and marked as per Georgia Standard 9106 "Traffic Control Detail for Lane Closure on Multi-Lane Divided Highway" or Georgia Standard 9107 "Traffic Control Detail for Lane Closure on Multi-Lane Undivided Highway". However, lane closures that exist for a duration longer than three ( $> 3$ ) calendar days may be signed and marked as per the details in Georgia Standard 9121 "Tapers, Signs, and Markings for Passing Lanes", provided the prior approval of the Engineer is obtained. The approved lane drop shall utilize only the signs and markings shown for the termination end of the lane drop in Georgia Standard 9121. All warning signs in the lane

drop sequence shall be used. Drums may be substituted for the Type I Crystal Delineators at the same spacing.

## **B. Shoulder Closures**

In accordance with MUTCD 6G.07, when paved shoulders, having a width of eight feet ( $\geq 8'$ ) or more are closed, at least one (1) advance warning sign shall be used. The sign(s) should read SHOULDER CLOSED (W21-5a). The signs are only posted on the side with the shoulder closure. Where the downstream end of the shoulder closure extends beyond the distance that can be perceived by road users, a supplementary plaque bearing the message NEXT XX FEET(W16-4P) or MILES (W7-3aP) should be placed below the SHOULDER CLOSED (W21-5a) sign. These signs shall be placed 500 feet prior to the shoulder closure. For multi-shoulder closures, the Shoulder Closed sign shall be repeated after two (2) miles at 500 feet prior to the next shoulder closure.

A shoulder closure will require a shoulder taper of  $(1/3)L$  ( $L$ =merging taper length). Traffic drums shall be used for the taper. Arrow boards are not required.

If positive barriers are used to closed the shoulder, the taper and drums shall be in accordance with Standard 4960, Temporary Barrier (End Treatment Options). The approach end of the barrier taper should be 10:1 or flatter slope.

## **C. Lane Closure**

### **1. Advance Warning Signs**

The advance Warning signs shall be in accordance with MUTCD and Georgia Standard 9106 "Traffic Control Detail for Lane Closure on Multi-Lane Divided Highway" and Georgia Standard 9107 "Traffic Control Detail for Lane Closure on Multi-Lane Undivided Highway".

When the temporary traffic control zone already has advanced warning (W20-1) signs installed the W20-1 signs required for lane closures under Standard 9106 and 9107 should be eliminated.

For Interstate, Limited Access and Multi-lane Divided Highways, an additional Portable Changeable Message Sign (PCMS) shall be placed one (1) mile in advance of a lane closure with a message denoting the appropriate lane closure one (1) mile ahead. No other message shall be displayed on this PCMS. The PCMS shall be placed on the outside shoulder in accordance with Detail 150-B [PCMS]. This is in addition to the other traffic control devices required by Standard 9106.

At the discretion of the Engineer, the Contractor may start placing advance warning signs a half-hour (1/2 hr.) prior to the lane closure.

### **2. Transition Area – Taper**

Drums shall be used on all transition tapers. If traffic drums with retroreflectivity of less than type VI are used for a merge taper that exists into the night, all drums located in the taper shall have, for the length of the taper only, a six inch (6") fluorescent orange (ASTM Type VI, VII, VIII, IX or X) reflectorized top stripe on each drum. The top six inch (6") stripe may be temporarily attached to the drum while in use in a taper. The Engineer may allow the fluorescent orange reflectorized six inch (6") top stripe on each drum in a merging taper to remain in place during daylight hours provided there is a lane closure(s) with a continuous operation that begins during one nighttime period and ends during another nighttime period. All drums that have the six inch (6") top stripe permanently attached shall not be used for any other conditions.

In accordance with MUTCD (6C.08), the minimum length for a merging taper for a lane closure on the travel way shall be as shown in Table 150-1:

**TABLE 150-1**

Posted Speed Limit, MPH	Lane Width 9 Feet	Lane Width 10 Feet	Lane Width 11 Feet	Lane Width 12 Feet	Maximum Drum Spacing in Tapers, (Feet)
	Minimum Taper Length (L) in Feet				
20	60	70	75	80	20
25	95	105	115	125	25
30	135	150	165	180	30
35	185	205	225	245	35
40	240	270	295	320	40
45	405	450	495	540	45
50	450	500	550	600	50
55	495	550	605	660	55
60	540	600	660	720	60
65	585	650	715	780	65
70	630	700	770	840	70
75	675	750	825	900	75

If site conditions require a longer taper, then the taper shall be lengthened to fit particular individual situations.

The length of shifting tapers should be at least one-half (1/2) L. Multiple Lane

Closures:

- a. A maximum of one (1) lane at a time shall be closed with each merge taper.
- b. A minimum tangent length of two ( $\geq 2$ ) L shall be installed between each individual lane closure taper. The tangent length is part of the transition area. Therefore, only traffic drums can be used in the tangent.

### 3. Activity Area

The activity area consists of a buffer and the work space. Georgia Standard 9106 "Traffic Control Detail for Lane Closure on Multi-Lane Divided Highway" states "Buffer zones of 300' minimum, 500' desirable are required for tangent sections and shall be increased for horizontal or vertical curves due to sight distance considerations"

Georgia Standard 9107 "Traffic Control Detail for Lane Closure on Multi-Lane Undivided Highway" requires a fifty feet (50') buffer. The buffer shall be increased for horizontal or vertical curves due to sight distance considerations"

The channelization devices are spaced at a maximum of eighty feet (80').

#### 4. Termination Area

Georgia Standard 9106 “Traffic Control Detail for Lane Closure on Multi-Lane Divided Highway” requires a 150 feet buffer and a minimum 200 feet downstream taper.

Georgia Standard 9107 “Traffic Control Detail for Lane Closure on Multi-Lane Undivided Highway” requires 150 feet downstream taper.

#### **D. Removal of Lane Closures**

To provide the greatest possible convenience to the public in accordance with Section 107, the Contractor shall remove all signs, lane closure markings, and devices immediately when lane closure work is completed or temporarily suspended for any length of time or as directed by the Engineer. All portable signs and portable sign mounting devices shall be removed from the roadway to an area which will not allow the sign to be visible and will not allow the sign or sign mounting device to be impacted by traffic. All devices shall be stored beyond the clear zone or behind positive protection.

#### **E. Exit and Entrance Ramps**

On multi-lane highways, where traffic has been shifted to the inside lanes, the exit and entrance ramps shall have drums placed on both sides of the ramp. This requirement will apply to any situation where traffic is shifted to contra flows or inside staging lanes to facilitate reconstruction work in the vicinity of exit and entrance ramps. The temporary ramp taper length should be greater than, or equal to, the existing taper length. Interim EXIT gore signs shall be placed at the ramp divergence. The “EXIT OPEN” sign shown in Figure TA- 42 of the MUTCD shall be utilized. For exit ramps, drums spacing shall be decreased to ten feet (10’) for 200 feet in advance of the temporary gore, and be decreased to ten feet (10’) for the first 100 feet of the temporary gore, and throughout the exit ramp. For on-ramps, drums should be used 200 feet prior to the ramp and end 100 feet past the merge taper. The drum spacing for the on ramp may be decreased but should not obstruct the view of the drivers i.e. for the ramp vehicles.

### **150.3.06 Traffic Pacing Method**

#### **A. Pacing Of Traffic**

With prior approval from the Engineer, traffic may be paced allowing the Contractor up to twenty (20) minutes maximum to work in or above all lanes of traffic for the following purposes:

1. Placing bridge members or other bridge work.
2. Placing overhead sign structures.
3. Other work items requiring interruption of traffic.

The Contractor shall provide a uniformed law enforcement officer with patrol vehicle and blue flashing light for each direction of pacing. The law enforcement officer, Engineer, and flaggers at ramps shall be provided with a radio which will provide continuous contact with the Contractor.

When ready to start the work activity, the law enforcement vehicle will act as a pilot vehicle slowing the traffic, thereby providing a gap in traffic allowing the Contractor to perform the Work. Any on-ramps between the pace and the work area shall be blocked during pacing of traffic, with a flagger properly dressed and equipped with a Stop/Slow paddle. Each ramp should be opened after the law enforcement vehicle has passed.

Pilot vehicles shall travel at a safe pace speed. The Contractor shall provide a vehicle to proceed in front of the law enforcement vehicle and behind the other traffic in order to inform the Contractor's work force when all vehicles have cleared the area.

Traffic should not be permitted to stop during pacing unless approved by the Engineer.

#### **B. Methods of Signing For Traffic Pacing**

At a point not less than 1,000 feet in advance of the beginning point of the pace, the Contractor shall place a portable changeable message sign with the message "TRAFFIC SLOWED AHEAD SHORT DELAY".

### **150.3.07 Flagging Operations**

#### **A. Flaggers**

Flaggers shall be provided as required to handle traffic, as specified in the Plans or Special Provisions, and as required by the Engineer.

#### **B. Flagger Certification**

All flaggers shall meet the requirements of the MUTCD and shall have received training and a certificate upon completion of the training from one of the following organizations:

National Safety Council

American Traffic Safety Services Association (ATSSA)

On-line classes are not accepted.

Failure to provide certified flaggers as required above shall be reason for the Engineer suspending work involving the flagger(s) until the Contractor provides the certified flagger(s). Flaggers shall have proof of certification and valid identification (photo I.D.) available any time they are performing flagger duties.

#### **C. Flagger Appearance and Equipment**

Flaggers shall wear Performance Class 3 or better high-visibility clothing. Flagger stations shall be illuminated at night according to MUTCD (6F.82). They shall use a Stop/Slow paddle meeting the requirements of the MUTCD (6E.03) for controlling traffic. The Stop/Slow paddles shall have a shaft length of seven feet ( $\geq 7'$ ) minimum. The Stop/Slow paddle shall be retroreflectorized for both day and night usage. In addition to the Stop/Slow paddle, a flagger may use a flag as an additional device to attract attention. This flag shall meet the minimum requirements of the MUTCD (6E.03). The flag shall, as a minimum, be twenty-four inches ( $\geq 24"$ ) square and red or red/orange in color.

#### **D. Flagger Warning Signs**

Signs for flagger traffic control shall be placed in advance of the flagging operation, in accordance with the MUTCD and Georgia Standard 9102 “Traffic Control Detail for Lane Closure on Two-Lane Highway”. In addition, signs at regular intervals, warning of the presence of the flagger shall be placed beyond the point where traffic can reasonably be expected to stop under the most severe conditions for that day’s work.

#### **E. Pilot Vehicle Requirements**

Pilot vehicles should be required during placement of bituminous surface treatment or asphaltic concrete on two-lane roadways unless otherwise specified. Pilot vehicles shall meet the requirements of the MUTCD (6C.13).

#### **F. Automated Flagger Assistance Devices**

The Contractor may request, in writing, the use of Automated Flagger Assistance Devices (AFAD). The equipment shall meet the requirements of MUTCD (6E.04). As a part of this request, the Contractor shall also submit an alternate temporary traffic control plan in the event of a failure of the AFAD. Any alternate plan that requires the use of flaggers shall include the use of certified flaggers. The Contractor shall obtain the approval of the Engineer before the use of any AFAD will be permitted.

#### **G. Portable Temporary Traffic Control Signals**

The Contractor may request, in writing, the substitution of portable temporary traffic control signals for flaggers on two-lane two-way roadways provided the temporary signals meets the requirements of the MUTCD, Section 647, and subsection 150.2.11. As a part of this request, the Contractor shall also submit an alternate temporary traffic control plan in the event of a failure of the signals. Any alternate plan that requires the use of flaggers shall include the use of certified flaggers. The Contractor shall obtain the approval of the Engineer before the use of any portable temporary traffic control signals will be permitted.

### **150.3.08 Traffic Signals**

#### **A. Responsibility/Cost**

If the sequence of operations, staging, or the temporary traffic control plan requires the relocation or shifting of any components of an existing traffic signal system then any work on these traffic signals will be considered as part of Traffic Control – Lump Sum.

#### **B. Law Enforcement Officer Requirement**

In accordance with Georgia law § 40-6-20, law enforcement officers shall be used to regulate and maintain traffic control at functioning signalized intersections when lane closures or traffic shifts block or restrict movements causing interference with road user flows and will not allow the activated traffic signal to guide the traffic through the signal site.

#### **C. Variable Message Board Requirement**

Variable Message Boards will be required at all intersection approaches of new signal installations for seven (7) days prior to the traffic signal activation. No separate pay item will be included; the cost of these variable message boards will be included in the the Lump Sum price bid for Traffic Signal Installation.

### 150.3.09 Mobile Operations

A mobile operation is defined by a minimum speed of three (3) mph. When pavement markings (centerlines, lane lines, and edge lines) are applied in a continuous operation by moving vehicles and equipment, the following minimum equipment and warning devices shall be required. These devices and equipment are in addition to the minimum requirements of the MUTCD.

All vehicles shall be equipped with the official slow moving vehicle symbol sign. All vehicles shall have a minimum of two (2) flashing or rotating beacons visible in all directions. All protection vehicles shall have an arrow panel mounted on the rear. All vehicles requiring an arrow panel shall have, as a minimum, a Type B panel. All vehicle mounted signs shall be mounted with the bottom of the sign a minimum height of forty-eight inches (48") above the pavement. All sign legends shall be covered or removed from view when work is not in progress.

The lead vehicle may be a separate vehicle or the work vehicle applying the pavement markings may be used as the lead vehicle. The lead vehicle shall have an arrow panel mounted so that the panel is easily visible to oncoming (approaching) traffic. The arrow panel should operate in the caution mode.

The work vehicle(s) applying markings shall have an arrow panel mounted on the rear. The arrow panel should typically operate in the caution mode. The work vehicle placing cones shall follow directly behind the work vehicle applying the markings.

A protection vehicle shall follow the last work vehicle at all times and shall be equipped with a truck mounted attenuator that shall be certified for impacts not less than sixty-two (62) mph in accordance with MASH/NCHRP350 Test Level Three (3).

### 150.3.10 Pavement Markings

#### A. General

Full pattern pavement markings in conformance with Section 3A and 3B, except 3B.02, of the MUTCD are required on all courses before the roadway is opened to traffic, unless noted in this section. No passing zones shall be marked to conform to Subsection 150.3.10.D.1.b. During construction and maintenance activities on all highways open to traffic, both existing markings and markings applied under this Section shall be fully maintained until Final Acceptance. If the pavement markings are, or become, unsatisfactory in the judgment of the Engineer due to wear, weathering, or construction activities, they shall be restored immediately.

Markings on the final surface course, which must be removed, shall be a removable type. The Contractor will be permitted to use paint, thermoplastic, or tape on pavement which is to be overlaid as part of the project, unless otherwise directed by the Engineer. Partial (skip) reflectorization (i.e. reflectorizing only a portion of a stripe) will not be allowed.

#### 1. Resurfacing Projects

Pavement markings shall be provided on all surfaces that are placed over existing markings. Interim and final markings shall conform in type and location to the markings that existed prior to resurfacing unless changes or additions are noted in the Contract. The replacement of parking spaces will not be required unless a specific item or note has been included in the Contract. Any work to make additions to the markings that existed prior to resurfacing is to be considered as extra work.

## 2. Widening And Reconstruction Projects

If the lane configuration is altered from the preconstruction layout then pavement markings will be as required by the plans or the Engineer.

## 3. New Location Construction Projects

Pavement marking plans will be provided.

# **B. Installation and Removal of Pavement Markings**

## 1. Installation

All pavement markings, both interim and permanent, shall be applied to a clean surface. The Contractor shall furnish the layout and preline the roadway surface for the placement of pavement markings applied as part of the temporary traffic control plan. All interim marking tape and RPM's on the final surface shall be removed prior to the placement of the final markings.

The Contractor shall sequence the work in such a manner as to allow the installation of markings in the final lane configuration at the earliest possible stage of the work.

## 2. Removal

Markings no longer applicable shall be removed in accordance with Section 656.

The elimination of conflicting pavement markings by overpainting with unapproved paint or any type of liquid asphalt is not acceptable.

## 3. Intermediate Surface

Interim markings shall be removed by methods that will cause minimal damage to the pavement surface, while also ensuring that traveling public will not be confused or misdirected by any residual markings remaining on the intermediate surface. The use of approved black-out tape and black-out paint (manufactured for the sole purpose of covering existing pavement markings) may be permitted on some interim surfaces, provided the results are satisfactory to the Engineer.

## 4. Final Surface

No interim paint or thermoplastic markings will be permitted on any final surface unless the interim markings are in alignment with the location of the permanent markings and the interim marking will not interfere or adversely affect placement of the permanent markings. The proposed method of removal for layout errors that require markings to be removed from the final surface shall have the prior approval of the Engineer. Any damage to the final pavement surface caused by the pavement marking removal process shall be repaired at the Contractor's expense by methods acceptable and approved by the Engineer. Section 400 shall apply when corrective measures are required. The use of black-out tape or black-out paint will not be permitted under any circumstance to correct layout errors on any final surface.

Traffic shifts that are done on the final surface shall be accomplished using interim traffic marking tape that can be removed without any blemishing of the final surface. Interim traffic marking tape shall be used on any of the following final surfaces; asphaltic concrete, Portland cement concrete, and bridge deck surfaces. The contractor may propose alternate traffic markings and removal methods on the final surface. Submitted proposals shall include the type of material, method of removal and a cost comparison to the traffic marking tape method. Prior to any approval, the contractor shall field demonstrate to the satisfaction of the Engineer that the proposed traffic markings can be removed without any blemishing of the final surface. If the proposal is determined to be acceptable, a supplemental agreement will be executed prior to the installation of the proposed alternate traffic markings. The supplemental agreement shall denote the type of

traffic marking materials, method of removal and any cost and/or time savings to the Department. The Department will not consider or participate in any cost increase that may result from implementing the proposed alternate method.

#### 5. Pay Factor Reduction for Asphaltic Concrete Final Surfaces

When the correction of an error in the layout of the final pavement markings requires the final surface to be grounded, blemished, scarred, or polished the pay factor shall be reduced to 0.95 for the entire surface area of the final topping that has a blemish, polished or a scarred surface. The reduced pay factor shall not be confined to only the width and length of the stripe or the dimensions of the blemished areas, the whole roadway surface shall have the reduced pay factor applied. The area of the reduced pay factor shall be determined by the total length and the total width of the roadway affected. If the affected area is not corrected, the reduction in pay shall be deducted from the final payment for the topping layer of asphaltic concrete. The Engineer shall make the final determination whether correction or a reduced pay factor is acceptable.

The eradication of pavement markings on intermediate and final concrete surfaces shall be accomplished by a method that does not grind, polish, or blemish the surface of the concrete. The method used for the removal of the interim markings shall not spall chip the joints in the concrete and shall not damage the sealant in the joints. Any joint or sealant repairs shall be included in the bid price for Traffic Control-Lump Sum. The proposed method of removal shall have the prior approval of the Engineer.

Failure to promptly remove conflicting or non-applicable pavement markings shall be considered as non-performance under Subsection 150.7.01.

#### 6. Preparation and Planning For Traffic Shifts

When shifting of traffic necessitates removal of centerline, lane lines, or edge lines, all such lines shall be removed prior to, during, or immediately after any change so as to present the least interference with traffic. Interim traffic marking tape shall be used as a temporary substitute for the traffic markings being removed.

Before any change in traffic lane(s) alignment, marking removal equipment shall be present on the project for immediate use. If marking removal equipment failures occur, the equipment shall be repaired or replaced (including leasing equipment if necessary), so that the removal can be accomplished without delay.

Except for the final surface, markings on asphaltic concrete may be obliterated by an overlay course, when approved by the Engineer. When an asphaltic concrete overlay is placed for the sole purpose of eliminating conflicting markings and the in place asphaltic concrete section will allow, said overlay will be eligible for payment only if designated in the Plans. Overlays to obliterate lines will be paid for only once and further traffic shifts in the same area shall be accomplished with removable markings. Only the minimum asphaltic concrete thickness required to cover lines will be allowed. Excessive build-up will not be permitted. When an overlay for the sole purpose of eliminating conflicting markings is not allowed, the markings no longer applicable shall be removed in accordance with Section 656.

### C. Raised Pavement Markers

Retroreflective raised pavement markers (RPMs) should be placed as listed below for all asphaltic concrete pavements before the roadway is open to traffic, unless noted this section. On the final surface, RPM's shall be placed according to the timeframes specified in Subsection 150.3.10.D for full pattern pavement markings. When Portland Cement Concrete is an intermediate or final surface and is open to traffic, one (1) calendar day is allowed for cleaning and drying before the installation of RPMs is required.

Raised pavement markers are not allowed on the right edge lines under any situation.

Retroreflective raised pavement markers (RPMs) should be placed and/or maintained on intermediate pavements surfaces on all highways that are open to traffic. This includes all resurfacing projects along with widening and reconstruction projects. The RPMs shall be placed as follows:

1. Supplementing Lane Lines:
  - a. Eighty foot (80') center on skip lines with curvature less than three degrees. (Includes tangents)
  - b. Forty foot (40') centers on solid lines and all lines with curvature between three degrees and six degrees.
  - c. Twenty foot (20') centers on curves over six degrees.
  - d. Twenty foot (20') centers on lane transitions or shifts.
2. Supplementing Ramp Gore Lines:
  - a. Twenty foot (20') centers, two each, placed side by side.
3. Other Lines:
  - a. As shown on the plans or directed by the Engineer.

#### **D. Exceptions for Interim Markings**

Some exceptions to the time of placement and pattern of markings are permitted as noted below; however, full pattern pavement markings are required for the completed project.

1. Two-Lane, Two-Way Roadways
  - a. Skip Lines

If used, interim temporary tape or paint skip (broken) stripe may only be used for a maximum of three (3) calendar days. The stripes shall be at least two feet ( $> 2'$ ) long with a maximum gap of thirty-eight feet ( $\leq 38'$ ). On curves greater than six degrees ( $>6^\circ$ ), a one-foot ( $1'$ ) stripe with a maximum gap of nineteen feet ( $\leq 19'$ ) shall be used. In lane shift areas, solid lines will be required.

Interim raised pavement markers may be substituted for the interim skip (broken) stripes. If raised pavement markers are substituted for the two foot ( $2'$ ) interim skip stripe, three (3) markers spaced at equal intervals over a two feet ( $2'$ ) distance will be required. No separate payment will be made if the interim raised pavement markers are substituted for interim skip lines.

Interim raised pavement markers shall be retro-reflective, shall be the same color as the pavement markers for which they are substituted, and shall be visible during daytime.

The type of interim marker and method of attachment to the pavement shall be approved by the Office of Materials and Testing but in no case will the markers be attached by the use of nails. Flexible reflective markers, Type 14 or Type 15, may be used for a maximum of three (3) calendar days as an interim marker. Any flexible reflective markers in use shall be from the QPL-76.

The interim raised pavement markers shall be maintained until the full pattern pavement markings are applied. At the time full pattern markings are applied the interim raised markers shall be removed in a manner that will not interfere with application of the full pattern pavement markings.

b. No Passing Zones Two-Lane, Two-Way Roadways

Passing zones shall be re-established in the locations existing prior to resurfacing. No changes to the location of passing zones shall be done without the written approval of the Engineer. For periods not to exceed three (3) calendar days where interim skip centerlines are in place, no-passing zones shall be identified by using post or portable mounted DO NOT PASS regulatory signs (R4-1) twenty-four inches by thirty inches ( 24" x 30") at the beginning and at intervals not to exceed one-half ( $\leq 1/2$ ) mile within each no-passing zone. A post or portable mounted PASS WITH CARE regulatory sign (R4-2) twenty-four inches by thirty inches ( 24" x 30") shall be placed at the end of each no-passing zone. Post mounted signs shall be placed in accordance with the MUTCD. Portable signs shall be secured in such a manner to prevent misalignment and minimize the possibility of being blown over by weather conditions or traffic.

On new location projects and on projects where either horizontal or vertical alignments has been modified, the location of No-Passing Zones will be identified by the Engineer.

c. Edge lines

- Bituminous Surface Treatment Paving

Edge lines will not be required on intermediate surfaces (including asphaltic concrete leveling for bituminous surface treatment paving) that are in use for a period of less than sixty (<60) calendar days except at bridge approaches, on lane transitions, lane shifts, and in such other areas as determined by the Engineer. On the final surface, edge lines shall be placed within thirty ( $\leq 30$ ) calendar days of the time that the final surface was placed.

- All Other Types of Pavement

Edge lines will not be required on intermediate surfaces that are in use for a period of less than thirty (<30) calendar days except at bridge approaches, on lane transitions, lane shifts, and in such other areas as determined by the Engineer. On the final surface, edge lines shall be placed within fourteen ( $\leq 14$ ) calendar days of the time that the surface was placed.

2. Multi-Lane Highways – With No Paved Shoulder(s) or Paved Shoulder(s) Four Feet or Less ( $\leq 4'$ )

a. Undivided Highways (Includes Paved Center Turn Lane)

- Centerlines and No-Passing Barrier-Full Pattern centerlines and no-passing barriers shall be restored before opening to traffic.
- Lane lines- Interim skip (broken) stripe as described in Subsection 150.3.10.D.1.a. may be used for periods not to exceed three ( $\leq 3$ ) calendar days. Skip lines are not permitted in lane shift areas. Solid lines shall be used.
- Edge lines- Edge lines shall be placed on intermediate and final surfaces within three (3) calendar days of obliteration.

b. Divided Highways (Grass or Raised Median)

- Lane lines- Full pattern skip stripe shall be restored before opening to traffic. Skip lines are not permitted in lane shift areas. Solid lines shall be required.
- Centerline/Edge line- Solid lines shall be placed on intermediate and final surfaces within three calendar days of obliteration.

3. Limited Access Roadways and Roadways with Paved Shoulders Greater Than Four Feet (> 4')
  - a. Same as Subsection 150.3.10.D.2 except as noted in (b) below.
  - b. Edge lines-
    - Asphaltic Concrete Pavement- Edge lines shall be placed on intermediate and final surfaces prior to opening to traffic.
    - Portland Cement Concrete Pavement- Edge lines shall be placed on any surface open to traffic no later than one calendar day after work is completed on a section of roadway. All water and residue shall be removed prior to daily striping.

#### 4. Ramps for Multi-Lane Divided Highways

A minimum of one solid line edge stripe shall be placed on any intermediate surface of a ramp prior to opening the ramp to traffic. The other edge stripe may be omitted for a maximum period of three (3) calendar days on an intermediate surface. Appropriate channelization devices shall be spaced at a maximum of twenty-five feet (25') intervals until the other stripe has been installed.

The final surface shall have both stripes placed prior to opening the ramp to traffic.

#### 5. Miscellaneous Pavement Markings

##### a. Final Surface

School zones, railroads, symbols, words and other similar markings shall be placed on final surfaces conforming to Section 652 within fourteen (14) calendar days of completion of the final surface. Final markings shall conform to the type of pay item in the plans. When no pay item exists in the plans the final markings shall conform to Section 652 for painted markings.

##### b. Intermediate Surface

Intermediate surfaces that will be in use for more than forty-five (45) calendar days shall have the miscellaneous pavement markings installed to conform to the requirement of Section 652. Under Subsection 150.6, Special Conditions, or as directed by the Engineer these markings may be eliminated.

##### c. Stop Line

All stop signs and traffic signals shall have temporary twelve inch (12") stop lines placed in accordance with MUTCD (3B.16) on all surfaces prior to opening to traffic. Temporary tape can be used.

### 150.3.11 Differences In Elevations Between Travel Lanes And Shoulders

All time frames and requirements may be changed with the Engineer's approval.

#### A. Differences in Elevations

Difference in elevations due to construction between travel lanes and/or shoulders within the clear zone should be limited to the following:

1. Difference of two inches ( $\leq 2''$ ) or less between adjacent travel lanes should remain for a maximum period of fourteen (14) calendar days.
2. Difference of two inches ( $\leq 2''$ ) or less between adjacent travel lane and paved shoulder should remain for a maximum of thirty (30) calendar days. Traffic control devices shall be in accordance with Detail 150-G.
3. Difference of greater than two inches ( $> 2''$ ) is permitted for continuous operations. Traffic control devices shall be in accordance with Detail 150-E.
4. Difference of greater than two inches ( $> 2''$ ) between travel lanes and/or shoulders for non-continuous operations will not be allowed for more than a twenty-four (24) hour period. For the first twenty-four (24) hours, traffic control shall be in accordance with Detail 150-E. After twenty-four (24) hours the section should be healed according to Detail 150-H. This condition can exist for a maximum sixty (60) calendar days.
  - a. A single length of area that does not exceed 1000 feet total length may be left open as a startup area for periods not to exceed forty-eight (48) hours provided the Contractor can demonstrate the ability to complete the Work in a proficient manner. Prior approval of the Engineer shall be obtained before any startup area may be allowed.
  - b. For cement stabilized base, work adjacent to the travel lane and/or shoulders shall be healed as per Detail 150-H within forty-eight (48) hours after the seven (7) calendar day curing period is complete for each section placed. During the placement and curing period, traffic control shall be in accordance Detail 150-E.

Failure to meet these requirements shall be considered as non-performance of Work under Subsection 150.7.01.

### **B. Healed Section**

Healed section and traffic control devices should be placed in accordance with Detail 150-H. If crushed stone materials are used to provide a healed section no separate payment will be made for the material used to heal any section. The Contractor may submit a plan to utilize existing pay items for crushed stone provided the plan clearly demonstrates that the materials used to heal an area will be incorporated into the work with minimal waste. Handling and hauling of any crushed stone used to heal shall be kept to a minimum. The Engineer shall determine if the crushed stone used to heal meets the specifications for gradation and quality when the material is placed in the final location.

### **C. Emergency Situations**

Inclement weather, traffic accidents, and other events beyond the control of the Contractor may prevent the work from being completed as required above. The Contractor shall notify the Engineer in writing stating the conditions and reasons that have prevented the Contractor from complying with the time limitations. The Contractor shall also outline a plan detailing immediate steps to complete the work. Failure to correct these conditions on the first calendar day that conditions will allow corrective work shall be considered as non-performance of Work under Subsection 150.7.01.

#### **D. Plating**

Plating for drainage structures, utility facilities, etc. is prohibited on the interstates. Plating on State Routes and secondary roads will required the prior approval of the project engineer. Steel plates shall not be used on highways with a posted speed greater than forty-five (45) mph. The plate shall completely cover the pavement cut or excavation. The plate shall be adequately secured and shall provide a safe and reasonable transition to the adjoining roadway surface. An asphalt wedge can be used to provide a smooth transition over the plate(s). Temporary traffic control warning signs W8-24 shall be posted in advance warning motorist about plates in roadway in accordance with the MUTCD. Plating should not remain in place for more than four (4) calendar days.

#### **E. Asphaltic Concrete Resurfacing Projects**

##### **1. Shoulder Construction Included as a Part of the Contract**

When the placement of asphaltic concrete materials creates a difference in elevation greater than two inches ( $> 2''$ ) between the earth shoulder (grassed or un-grassed) and the edge of travel lane or between the earth shoulder and a paved shoulder that is less than four feet ( $< 4'$ ) in width, the Contractor shall place and maintain drums in accordance with the requirements of Subsection 150.2.04.B.3. When the edge of the paved surface is tapered with a safety edge, drums may be spaced at two (2) times the speed limit in MPH. Drums shall remain in place and be maintained until the difference in elevation has been eliminated by the placement of the appropriate shoulder materials.

##### **2. Shoulder Construction Not Included as a Part of the Contract**

When the placement of asphaltic concrete materials creates a difference in elevation greater than two inches ( $> 2''$ ) between the earth shoulder (grassed or un-grassed) and the edge of travel lane or between the earth shoulder and a paved shoulder that is less than four feet ( $< 4'$ ) in width, the Contractor shall notify the Engineer, in writing, when the resurfacing work including all punch list items has been completed.

Drums spaced at twenty foot (20') intervals. <b>Note:</b> If the travel way width is reduced to less than ten feet (< 10') by the use of drums, vertical panels shall be used in lieu of drums.	Location of drums when Elevation Difference exceeds four inches (> 4")
---	--

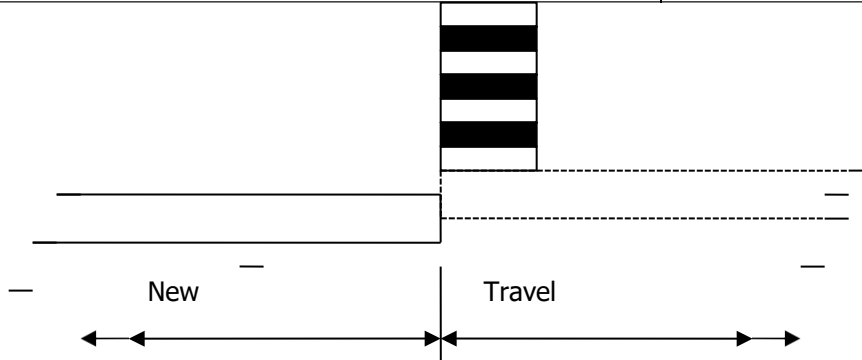

ELEVATION DIFFERENCE GREATER THAN FOUR INCHES (> 4")

DETAIL 150-E

Drums spaced at forty foot (40') intervals.	Location of drums when Elevation Difference is greater than two inches (> 2") to four inches (4")
---	---

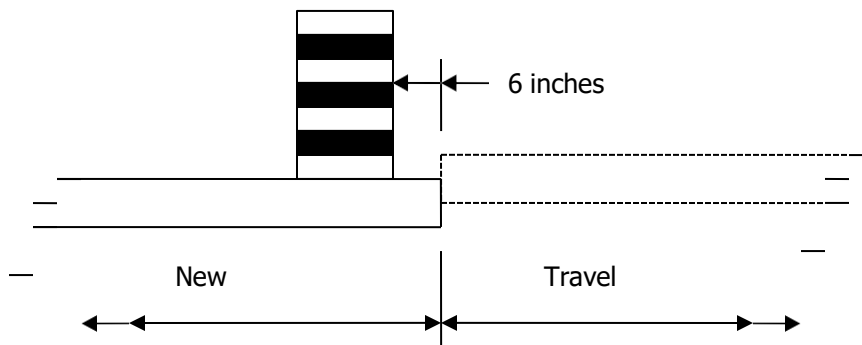

ELEVATION DIFFERENCE GREATER THAN TWO INCHES (> 2") TO FOUR INCHES (4")

DETAIL 150-F

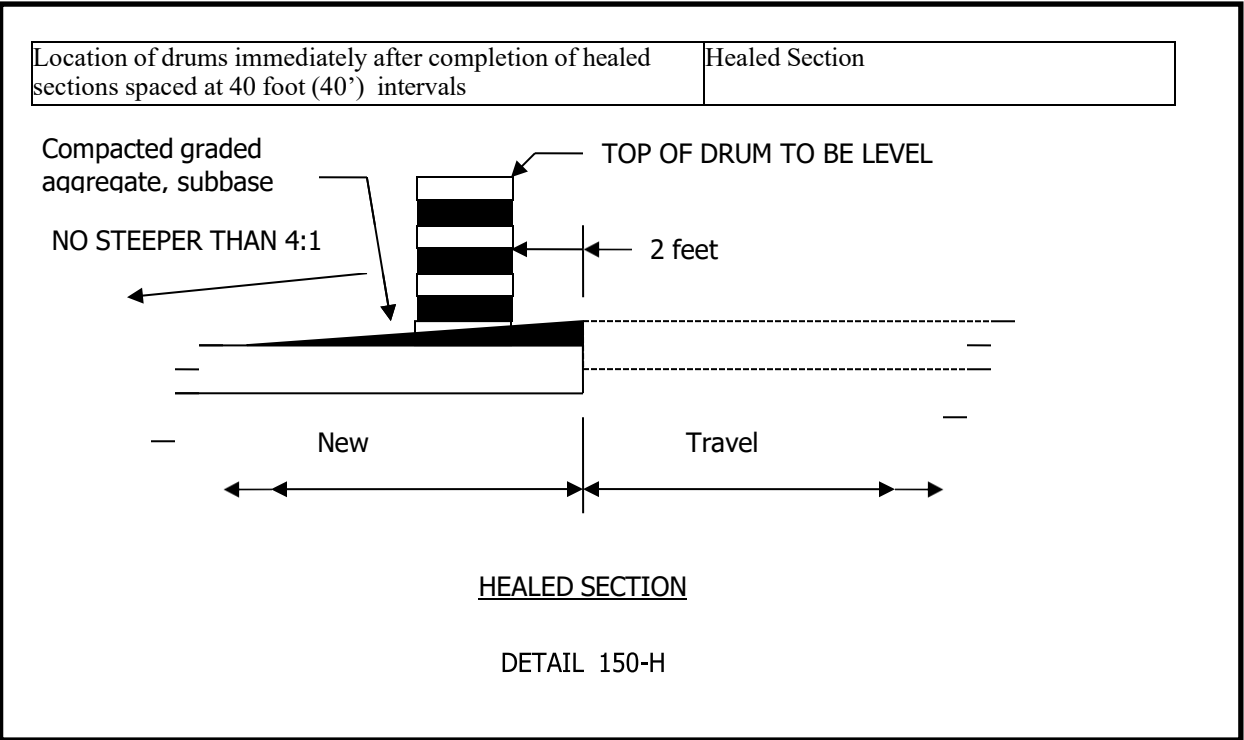
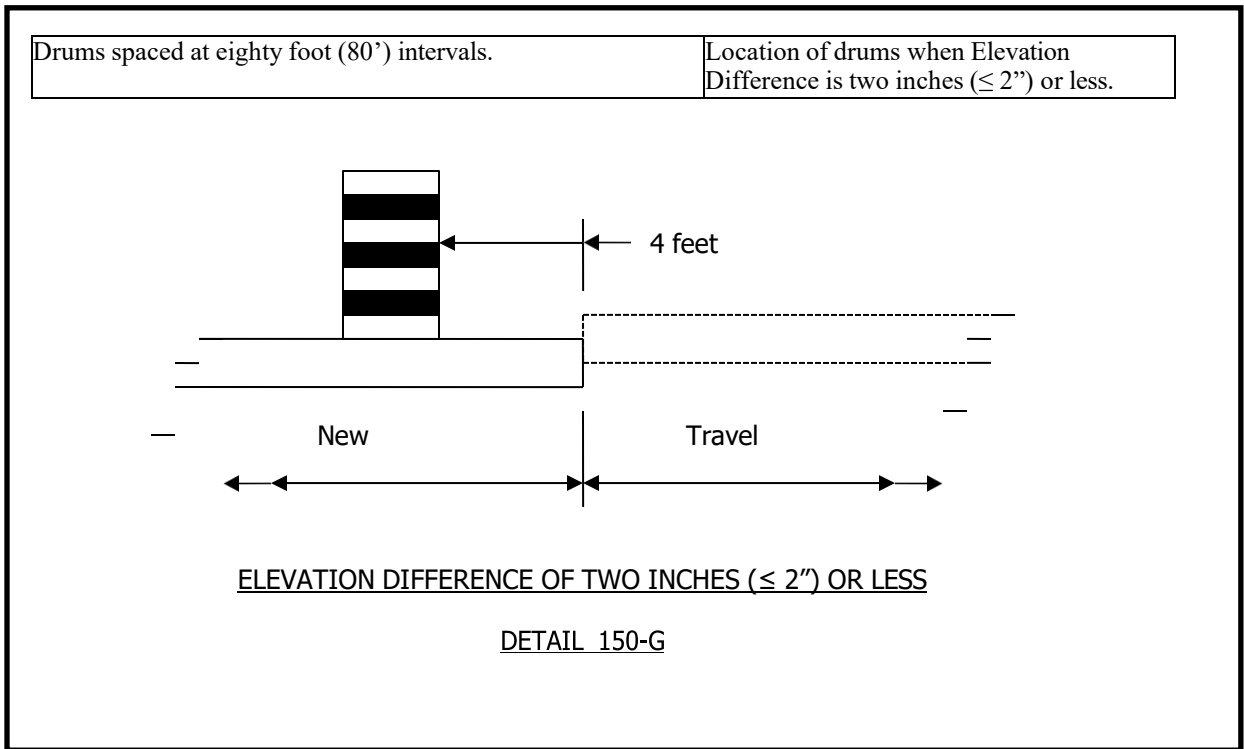

### **150.3.12 Work Zone Law Enforcement**

Work zone law enforcement consists of utilizing a uniformed law enforcement officer equipped with patrol vehicle and blue flashing lights to enforce traffic laws in construction work zones and the administration of this service. Payment for work zone law enforcement will be made only for the utilization in work zones during lane closures, traffic pacing, or other activities that occur within travel lanes. The Contractor will be responsible for negotiating a rate of reimbursement and making reimbursement to that law enforcement agency.

The Contractor will be responsible for coordinating and scheduling the utilization of the work zone law enforcement. The Engineer may require the use of work zone law enforcement at specific times and locations.

## **150.4 Measurement**

### **150.4.01 Traffic Control Items**

#### **A. Traffic Control**

When listed as a pay item in the Proposal, payment will be made at the lump sum price bid, which will include all traffic control not paid for separately, and will be paid as follows:

When the first Construction Report is submitted, a payment of ten percent (10%) of the lump sum price will be made, but in no event shall the initial payment exceed two percent (2%) of the total contract value. For each progress payment thereafter, the total of the Project percent complete shown on the last pay statement plus ten percent (10%) will be paid (less previous payments), not to exceed one hundred percent (100%).

When no payment item for Traffic Control-Lump Sum is shown in the Proposal, all of the requirements of Section 150 and the Temporary Traffic Control Plan shall be in full force and effect. The cost of complying with these requirements will not be paid for separately, but shall be included in the overall bid submittal.

#### **B. Changeable Message Sign, Portable**

Portable changeable message sign will be measured as specified in Section 632.

#### **C. Flashing Beacon Assembly**

Flashing beacon assemblies will be measured as specified in Section 647.

#### **D. Pavement Markings**

Pavement markings will be measured as specified in Section 150.

### **E. Portable Impact Attenuators**

Each portable impact attenuator will be measured by the unit/array which shall include all material components, hardware, incidentals, labor, site preparation, and maintenance, including spare parts recommended by the manufacturer for repairing accident damage. Each unit will be measured only once regardless of the number of locations installed, moves required, or number of repairs necessary because of traffic damage. Upon completion of the project, the units shall be removed and retained by the Contractor.

### **F. Signs**

When shown as a pay item in the contract, interim special guide signs will be paid for as listed below. All other regulatory, warning, and guide signs, as required by the Contract, will be paid for under Traffic Control Lump Sum or included in the overall bid submitted.

1. Interim ground mounted or interim overhead special guide signs will be measured for payment by the square foot. This payment shall be full compensation for furnishing the signs, including supports as required, erecting, illuminating overhead signs, maintaining, removing, re-erecting, and final removal from the Project. Payment will be made only one time regardless of the number of moves required.
2. Remove and reset existing special guide signs, ground mount or overhead, complete, in place, will be measured for payment per each. Payment will be made only one time regardless of the number of moves required.
3. Modify special guide signs, ground mount or overhead, will be measured for payment by the square foot. The area measured shall include only that portion of the sign modified. Payment shall include materials, removal from posts or supports when necessary, and remounting as required.

### **G. Temporary Audible Information Device**

Temporary audible information devices are measured as the actual number furnished and installed in accordance with the manufacturer's recommendations, which shall include all necessary materials, equipment, labor, site preparation, maintenance and removal. Each temporary audible information device will be paid for only one time regardless of the number of times it's reused during the duration of The Work. These devices shall remain the property of the Contractor.

### **H. Temporary Barrier**

Temporary barrier shall be measured as specified in Sections 620.

### **I. Temporary Curb Cut Wheelchair Ramps**

Temporary curb cut wheelchair ramps are measured as the actual number formed and poured, complete and accepted, which shall include all necessary materials, equipment, labor, site preparation, maintenance and removal. No additional payment will be made for sawing existing sidewalk and removal and disposal of removed material for temporary wheelchair ramp construction. No additional payment will be made for constructing the detectable warning surface.

**J. Temporary Guardrail Anchorage, Type 12**

Temporary guardrail anchorage- type 12 will be measured by each assembly, complete in place and accepted according to the details shown in the plans, which shall also include the additional guardrail and appurtenances necessary for transition and connection to temporary concrete barrier. Payment shall include all necessary materials, equipment, labor, site preparation, maintenance and removal.

**K. Temporary Walkways with Detectable Edging**

Temporary walkways with detectable edging will be measured in linear feet (meters), complete in place and accepted, which shall include all necessary materials, equipment, labor, site preparation, temporary pipes, passing spaces, maintenance and removal. Excavation and backfill are not measured separately for payment. No payment will be made for temporary walkways where existing pavements or existing edging (that meets the requirements of MUTCD) are utilized for the temporary walkway. Payment for temporary detectable edging, including approved barriers and channelizing devices, installed on existing pavement shall be included in Traffic Control-Lump Sum.

**L. Traffic Signal Installation- Temporary**

Temporary traffic signal installation will be measured as specified in Section 647.

**M. Work Zone Law Enforcement**

When work zone law enforcement is shown as a pay item, work zone law enforcement will be measured for payment by the hour. The Contractor shall provide a daily work record containing the actual number of hours charged by the law enforcement officer. The daily work record shall be compiled on a form provided by the Department, signed by the law enforcement officer, signed by the Contractor's Worksite Traffic Control Supervisor attesting that the law enforcement was utilized during the time recorded, and then submitted to the Engineer.

Work zone law enforcement will be measured for payment by the hour up to the maximum number of hours included in the contract. The Engineer may at his discretion increase the maximum number of hours.

Payment shall be full compensation for reimbursing the law enforcement agency, and for all cost incurred by the Contractor in coordinating, scheduling, and administering the item work zone law enforcement.

If no work zone law enforcement pay item is included in the contract, then all work zone law enforcement cost shall be included in Traffic Control – Lump Sum.

**150.5 Reserved****150.6 Special Conditions**

Special Conditions, if used, will be included elsewhere in the Contract.

**150.7 Payment**

When shown in the Schedule of Items in the Proposal, the following items will be paid for separately. Payment will be made under:

Item No. 150	Traffic control -	Lump sum
Item No. 150	Traffic control, solid traffic stripe ____ inch, (color)	Per linear mile
Item No. 150	Traffic control, skip traffic stripe ____ Inch, (color)	Per linear mile
Item No. 150	Traffic control, solid traffic stripe, thermoplastic 24 inch, color	Per linear mile
Item No. 150	Traffic control, raised pavement markers –all types	Per each
Item No. 150	Remove and reset, existing special guide signs, overhead, complete-in-place	Per each
Item No. 150	Temporary walkways with detectable edging	Per linear foot
Item No. 150	Temporary curb cut wheelchair ramps	Per each
Item No. 150	Temporary audible information device	Per each
Item No. 150	Single lane closure	Per each
Item No. 150	Multilane closure	Per each
Item No, 150	Work Zone Law Enforcement	Per hour

**150.7.01 Enforcement and Adjustments**

The safe passage of pedestrians and traffic through and around the temporary traffic control zone, while minimizing confusion and disruption to traffic flow, shall have priority over all other Contractor activities. Continued failure of the Contractor to comply with the requirements of Section 150 - Traffic Control will result in non-refundable deductions of monies from the Contract as shown in this Subsection for non-performance of Work.

Failure of the Contractor to comply with this Specification shall be reason for the Engineer suspending all other work on the Project, except erosion control and traffic control, taking corrective action as specified in Section 105, and/or withholding payment of monies due to the Contractor for any work on the Project until traffic control deficiencies are corrected. These other actions shall be in addition to the deductions for non-performance of traffic control.

<b>SCHEDULE OF DEDUCTIONS FOR EACH CALENDAR DAY OF DEFICIENCIES OF TRAFFIC CONTROL INSTALLATION AND/OR MAINTENANCE</b>		
<b>ORIGINAL TOTAL CONTRACT AMOUNT</b>		
<b>From More Than</b>	<b>To and Including</b>	<b>Daily Charge</b>
\$0	\$100,000	\$250
\$100,000	\$1,000,000	\$650
\$1,000,000	\$5,000,000	\$1,300
\$5,000,000	\$20,000,000	\$2,000
\$20,000,000	\$40,000,000	\$2,600
\$40,000,000	\$-----	\$4,000

# **APPENDIX A**

## **DEPARTMENT OF TRANSPORTATION GWINNETT COUNTY**

### **2023-MR PAVING LIST**

**Key:**

**CM – Curb Mill**

**CF – Crack Fill**

**P - Patch – Patching expected, TBD by engineer and field conditions**

**Level – leveling expected, TBD by engineer and field conditions**

**Shoulder – shoulder work required on some and/or entire roadway**

**MH – Manhole**

**WV – Water Valve**

**Bid tab notes:**

**Bid item #1 – 9.5mm GP type 2 at 125 lb/sy**

**Bid item #2 – 12.5mm GP type 2 at 165 lb/sy**

**Alt. Bid item #1 – 12.5mm GTR-Modified GP type 2 at 165 lb/sy**

**Alt. Bid item #2 – 12.5mm Polymer-Modified GP type 2 at 165 lb/sy**

**2025 Major Roads Supplemental - BL139-24 NORTH**

		Branch Name	Beginning	Ending	Length (feet)	Length (miles)	Width (feet)	Spread Rate	Type	Shoulder	Curb Mill	Crach Fill	Patching	Leveling	Manholes	Water Valves	Rumble	FINISH STRIPE
1	North	FENCE ROAD	HEBRON CHURCH ROAD	SR 316	7825	1.48	24	165	12.5mm	C&G / Earth	YES	YES	YES	YES			TBD	STD THERMO
2	North	RIDGE ROAD	HAMILTON MILL ROAD	THOMPSON MILL ROAD	5525	1.05	24	165	12.5mm	C&G / Earth	YES	YES	YES	YES		10	TBD	WW THERMO
3	North	TENCH ROAD	SUWANEE DAM ROAD	PEACHTREE INDUSTRIAL BLVD	3000	0.57	26	165	12.5mm	C&G / Earth	YES	YES	YES	YES			TBD	STD THERMO
4	North	CALVIN DAVIS CIRCLE	RUSSELL ROAD	SR 20	2420	0.46	24	165	12.5mm	C&G / Earth	YES	YES	YES	YES			TBD	STD THERMO
5	North	OLD PEACHTREE ROAD	SR 20	COLLINS HILL ROAD	11380	2.16	26	165	12.5mm	C&G / Earth	YES	YES	YES	YES	5	10	TBD	WW THERMO
6	North	SUWANEE DAM ROAD	LEVEL CREEK ROAD	JOHNSON ROAD	7505	1.42	24	165	12.5mm	C&G / Earth	YES	YES	YES	YES	2	3	TBD	WW THERMO
7	North	MALL of GEORGIA BLVD EB	SR 20	SR 324	7160	1.36	24	165	12.5mm	C&G	YES	YES	YES	YES	2	9	TBD	WW THERMO
8	North	MALL of GEORGIA BLVD WB	SR 324	SR 20	7160	1.36	24	165	12.5mm	C&G	YES	YES	YES	YES			TBD	WW THERMO
9	North	SUNNY HILL ROAD (FDR)	OLD PEACHTREE ROAD	MORGAN ROAD 500ft NE of Fieldview Drive	9,560	1.81	24	165	12.5mm	Earth	YES	YES	YES	YES	3	34	TBD	WW THERMO

**11.65**

Roads with Schools

**2025 Major Roads Supplemental - BL139-24 SOUTH**

		Branch Name	Beginning	Ending	Length (feet)	Length (miles)	Width (feet)	Spread Rate	Type	Shoulder	Curb Mill	Crack Fill	Patching	Leveling	Manholes	Water Valves	Rumble	FINISH STRIPE	
1	South	PINEHURST ROAD	NORTH ROAD	VALLEY CREEK CIRCLE (N. Entrance)	4460	0.84	24	165	12.5mm	C&G / Earth	YES	YES	YES	YES		1	TBD	STD THERMO	
2	South	PINEHURST ROAD	VALLEY CREEK CIRCLE	RIDGEDALE DRIVE	3190	0.6	22	165	12.5mm	C&G / Earth	YES	YES	YES	YES		2	TBD	STD THERMO	
3	South	SKYLAND DRIVE	US 78	ROCKDALE CIRCLE (SOUTH)	8510	1.61	26	165	12.5mm	C&G / Earth	YES	YES	YES	YES	18	2	TBD	STD THERMO	
4	South	HOKE O'KELLY MILL ROAD	SR 20	US 78	8030	1.52	22	165	12.5mm	Earth	YES	YES	YES	YES	3	6	TBD	STD THERMO	
5	South	SUGARLOAF PARKWAY EB - <b>Pave 6885'</b> <b>w/TrArea=260380sqft - skip 2135' paved @ new SD</b>	HWY 124	SR 20	6885	1.3	28	165	12.5mm	C&G	YES	YES	YES	YES	3		TBD	WW THERMO	
6	South	SUGARLOAF PARKWAY WB - <b>Pave 6885'</b> <b>w/TrueArea=241880SqFt - skip 2100' paved @ new SD</b>	SR 20	HWY 124	6885	1.3	28	165	12.5mm	C&G	YES	YES	YES	YES		12	TBD	WW THERMO	
7	South	ALCOVY ROAD	SWEETGUM ROAD	ALCOVY RIVER	4570	0.87	24	165	12.5mm	C&G / Earth	YES	YES	YES	YES		2	TBD	STD THERMO	
8	South	OLD LOGANVILLE ROAD	BRUSHY FORK ROAD	LOGANVILLE CITY LIMITS	3295	0.62	26	165	12.5mm	Earth	YES	YES	YES	YES			TBD	STD THERMO	
9	South	OLD LOGANVILLE ROAD	LOGANVILLE CITY LIMITS	US 78	9580	1.81	26	165	12.5mm	Earth	YES	YES	YES	YES	1	6	TBD	STD THERMO	
10	South	BRISCOE ROAD	HOKE O'KELLY MILL	OZORA CHURCH ROAD	5690	1.08	24	165	12.5mm	Earth	YES	YES	YES	YES	3	5	TBD	STD THERMO	
11	South	TRIBBLE MILL ROAD	OZORA ROAD	CALLIE STILL ROAD	5600	1.06	24	165	12.5mm	Earth	YES	YES	YES	YES			TBD	STD THERMO	
						<b>12.63</b>													

Roads with Schools

**2025 Major Roads Supplemental - BL139-24 WEST**

		Branch Name	Beginning	Ending	Length (feet)	Length (miles)	Width (feet)	Spread Rate	Type	Shoulder	Curb Mill	Crack Fill	Patching	Leveling	Speed Humps	Manholes	Water Valves	Rumble	FINISH STRIPE
1	West	OLD PEACHTREE ROAD	SUGARLOAF PARKWAY	420' W HIGHGATE HILLS DRIVE	2,420	0.46	48	165	12.5mm	C&G	YES	YES	YES	YES				TBD	WW THERMO
2	West	OLD PEACHTREE ROAD	420' W HIGHGATE HILLS DRIVE	LAKE LOUELA ROAD	3,010	0.57	38	165	12.5mm	C&G	YES	YES	YES	YES			7	TBD	WW THERMO
3	West	OLD PEACHTREE ROAD	DULUTH CITY LIMITS	SUGARLOAF PARKWAY	3,920	0.74	48	165	12.5mm	C&G	YES	YES	YES	YES				TBD	WW THERMO
4	West	THOMPSON PARKWAY	SINGLETON ROAD	LIVE OAK PARKWAY	1,075	0.20	38	165	12.5mm	C&G	YES	YES	YES	YES		6		TBD	WW THERMO
5	West	HOLCOMB BRIDGE ROAD	US 23	SOUTH PEACHTREE STREET	1,020	0.19	24	165	12.5mm	C&G	YES	YES	YES	YES		7	8	TBD	STD Thermo
6	West	BANK STREET (170' SW @ Pleasant Hill Rd new pvmt.!)	170' SW PLEASANT HILL ROAD	W END	345	0.07	28	165	12.5mm	C&G	YES	YES	YES	YES				TBD	STD Thermo
7	West	SOUTH OLD PEACHTREE ROAD	US 23	SOUTH BERKELEY LAKE ROAD	2,920	0.55	24	165	12.5mm	C&G / Earth	YES	YES	YES	YES			2	TBD	STD Thermo
8	West	TECH DRIVE	INDIAN TRAIL ROAD	SINGLETON ROAD	835	0.16	36	165	12.5mm	C&G	YES	YES	YES	YES				TBD	STD Thermo
9	West	WILLOW OAK TRAIL	INDIAN TRAIL ROAD	WILLOWTRAIL PARKWAY	775	0.15	36	165	9.5mm	C&G	YES	YES	YES	YES		3	1	TBD	STD Thermo
10	West	WILLOWTRAIL PARKWAY	INDIAN TRAIL ROAD	200' NE MAIN STREET	570	0.11	24	165	9.5mm	C&G	YES	YES	YES	YES				TBD	STD Thermo
11	West	ARC WAY	PLEASANT HILL ROAD	W END	1,910	0.36	24	165	9.5mm	C&G / Earth	YES	YES	YES	YES	4		2	TBD	STD Thermo 1st 100ft
12	West	FORK CREEK PARKWAY	US 29	WINDSTEAM WAY	1,450	0.27	26	165	12.5mm	C&G	YES	YES	YES	YES			4	TBD	WW THERMO
13	West	FORK CREEK PARKWAY	WINDSTREAM WAY	BETHESDA SCHOOL ROAD	2,995	0.57	24	165	12.5mm	C&G / Earth	YES	YES	YES	YES		1		TBD	WW THERMO
14	West	BOGGS ROAD - pave 4520' only (out of 6820')	OLD NORCROSS ROAD	I 85	4,520	0.86	62	165	12.5mm	C&G	YES	YES	YES	YES			1	TBD	WW THERMO
15	West	SATELLITE BOULEVARD SB	4150' N WILDWOOD ROAD	WILDWOOD ROAD	4,150	0.79	24	165	12.5mm	C&G	YES	YES	YES	YES				TBD	WW THERMO
16	West	SATELLITE BOULEVARD NB	WILDWOOD ROAD	4150' N WILDWOOD ROAD	4,150	0.79	24	165	12.5mm	C&G	YES	YES	YES	YES				TBD	WW THERMO
17	West	LEBANON ROAD	SR 120	900' N S R 120	900	0.17	24	125	9.5mm	C&G	YES	YES	YES	YES		5		TBD	WW THERMO
18	West	LEBANON ROAD	LULLWATER COURT	900' N SR120	3980	0.75	25	125	9.5mm	C&G	YES	YES	YES	YES		2		TBD	WW THERMO
19	West	LEBANON ROAD	LULLWATER COURT	SEVER ROAD	2100	0.40	26	125	9.5mm	C&G	YES	YES	YES	YES				TBD	WW THERMO
20	West	CAPITAL CIRCLE	PURCELL ROAD	S END	1350	0.26	30	165	12.5mm	C&G	YES	YES	YES	YES		3		TBD	WW THERMO
21	West	NORTHLAKE DRIVE	OLD PEACHTREE ROAD	NORTHBROOK PARKWAY	1890	0.36	28	165	12.5mm	C&G	YES	YES	YES	YES		5		TBD	WW THERMO
22	West	JIMMY CARTER BOULEVARD NB	HAYES DRIVE	I 85	2,705	0.51	48	165	12.5mm	C&G	YES	YES	YES	YES			6	TBD	WW THERMO
23	West	JIMMY CARTER BOULEVARD SB	I 85	HAYES DRIVE	2,705	0.51	36	165	12.5mm	C&G	YES	YES	YES	YES		2	5	TBD	WW THERMO

9.79

Roads with Schools

# **APPENDIX B**

**DEPARTMENT OF  
TRANSPORTATION GWINNETT  
COUNTY**

**2023-MR Resurfacing Map**

# GWINNETT COUNTY

## 2025 LMIG Paving Map

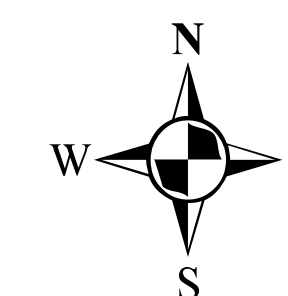

NORTH  
Paving Section

WEST  
Paving Section

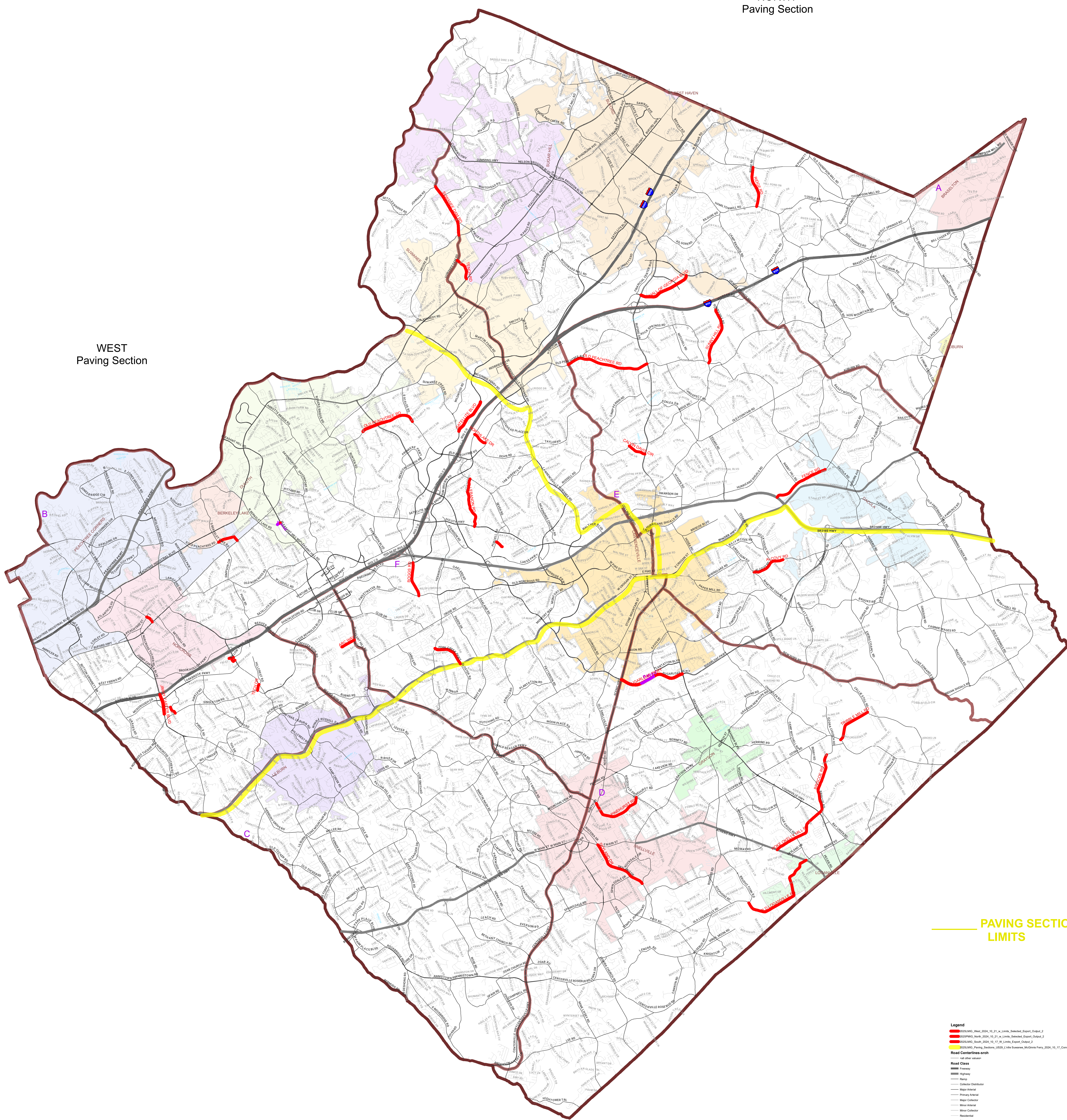

SOUTH  
Paving Section

PAVING SECTION  
LIMITS

**Legend**

- 2025 LMIG West 2024 to 21 to 1 mile, Section, Paper, Copy 2
- 2025 LMIG North 2024 to 21 to 1 mile, Section, Paper, Copy 2
- 2025 LMIG South 2024 to 21 to 1 mile, Section, Paper, Copy 2
- 2025 LMIG Paving Section 2024 to 21 to 1 mile, Section, Paper, Copy 2

**Road Centerlines** (in feet)

- Other values

**Road Class**

- Freeway
- Highway
- Loop
- Collector Distributor
- Major Arterial
- Primary Arterial
- Major Collector
- Minor Collector
- Residential
- Private

**AA\_City\_3000**

- Other values

**CITY\_NAME**

- DETERREY LAKE
- BRANDSTON
- ALBURN
- BATON
- CLAYTON
- DAKOTA
- DALTON
- GRAYSON
- HOSPITAL
- LANDSCAPEVILLE
- LEBURN
- LOUISVILLE
- NONCROSS
- PEACHTREE CORNERS
- WEST HAVEN
- SMELLYVILLE
- STANWELL
- SUNNACRE
- GA\_County